

Effect of Credit Risk Management Techniques on Financial Performance of Deposit Taking SACCOs in Kenya

Peruce Hoka Etenyi¹

Mary Nelima²

Muli Maingi³

¹peruhoka@gmail.com

²nelimasindani@yahoo.com

³wmmaingi@gmail.com

¹<https://orcid.org/0009-0007-3857-3882>

²<https://orcid.org/0000-0002-0451-539X>

³<https://orcid.org/0009-0005-5328-6641>

^{1,2,3}Department of Accounting and Finance, Masinde Muliro University of Science and Technology, Kenya

ABSTRACT

Financial performance is crucial in the realm of finance. The requirement to explain why two organizations operating in the same environment perform differently is a puzzle, and various financial research works have been devoted to solving this puzzle. Co-operative societies in Kenya are recognized as a significant contributor to national development since their presence can be traced in virtually all sectors of the economy. Although significant progress has been made by the deposit taking SACCOs in Kenya, their performance and sustainability has been debatable. The objective of this research was to assess the effect of financial risk management techniques on financial performance of deposit taking SACCOs in Kenya. The specific objective was to determine the effect of credit risk management techniques on financial performance of deposit taking SACCOs in Kenya. The study was based on Credit Risk Theory. A descriptive survey design was adopted. The population of the study was the 175-deposit-taking SACCOs in Kenya as of 31st December 2022. Due to relative population nature, sampling was not conducted and therefore the study was a census. The respondent was the risk manager of each deposit-taking SACCO. The study utilized primary data. The data was collected using a structured questionnaire. Data was analyzed using descriptive statistics such as the mean and standard deviation and inferential statistics which included correlation and regression analysis. Reliability tests were conducted on the variables each meeting the 0.7reliability threshold with validity tests being confirmed by the Bartlett's test that confirmed validity of the variables being measured. The regression analysis revealed significant insights into the relationship between financial risk management techniques and the financial performance of deposit-taking SACCOs in Kenya. Credit risk management techniques were found to have a positive impact on financial performance with a regression coefficient of $\beta = 0.238$ and a significant value of $P < 0.005$. In conclusion, the study provides compelling evidence of the importance of comprehensive risk management frameworks in driving the financial performance of deposit-taking SACCOs in Kenya. By implementing effective risk management practices tailored to address credit risk, SACCOs can enhance their stability, profitability, and resilience in a dynamic operating environment. These findings have significant implications for policymakers, practitioners, and stakeholders in the SACCO sector, highlighting the need to prioritize investments in risk management capabilities to promote sustainable financial growth. The study recommended that SACCOs should focus on enhancing their credit risk management frameworks. This can be achieved by implementing robust credit risk assessment mechanisms, such as comprehensive credit scoring models and regular analysis of customer credit histories.

Keywords: Credit Risk Management, Deposit-Taking Saccos, Financial Performance, Financial Risk Management

1. INTRODUCTION

A Savings and Credit Cooperative Society is a financial institution that is owned, controlled and operated by its members, providing them with access to loans at low interest rates, promoting thrift and providing alternative financial services, as the main purpose of their existence. They have controlled poverty through boosting strategies in wealth creation, production of food for subsistence and employment opportunities creation (FinAccess (2021).

According to Tapiero (2004), the origin of the contemporary cooperative idea can be traced back to 1844 in Rochdale village under Manchester, England. Internationally, it has subsequently evolved into a socioeconomic movement with its own unique history, objective, and character. The historical rural credit union was established in 1864 by Raiffeisen in Germany to address the financial requirements of individuals residing in remote areas

considered unbankable, such as rural communities with restricted cash flows and a scarcity of human resources (World Bank, 2007).

The inadequacy of the financial risk management measures used by Uganda's cooperative societies has ruined the financial sustainability of numerous groups and severely limited their capacity to extend credit, according to The inadequacy of the financial risk management measures used by Uganda's cooperative societies has ruined the financial sustainability of numerous groups and severely limited their capacity to extend credit, according to Orichom & Omeke (2020). Tassew et al. (2017) found that members of Ethiopian cooperative organizations have limited access to a variety of financial products. Since members could have other options and choices from commercial banks, their main rivals, this narrow range led to a decline in their performance. Tassew et al. (2017) found that members of Ethiopian cooperative organizations have limited access to a variety of financial products. Since members could have other options and choices from commercial banks, their main rivals, this narrow range led to a decline in their performance

The cooperative movement in Kenya began in 1931 with the regularisation of agricultural cooperatives. In response to several interactions by various stakeholders, the cooperative ordinance act was passed in 1945. Subsequently, in 1977, the existing cooperative society act Cap 490 of the Kenyan legislation was modified (Lagat et al., 2013). The statute mandates that in order for a society to be officially registered, it must have a minimum of ten members, the majority of whom are from the same community and engage in comparable economic endeavours.

Several commercial banks in Kenya, such as Equity Bank, Family Bank, and Unaitas, originated as Savings and Credit Cooperative Organisations (Sacco's) (Bruett, 2011). SACCOs in Kenya are essential for the economic development of its members. The SACCO movement in Kenya is so outstanding that it is considered the most dynamic in Africa and the seventh most prominent worldwide. SACCOs have effectively provided financial inclusion and banking services to a significant number of low-income households in Kenya, particularly in rural regions (Ochieng, 2021). An estimated 81% of Kenyans depend on Savings and Credit Cooperative Organizations (SACCOs) to obtain financial services in Kenya (Irusa, 2018).

According to Ochieng (2021) financial risk management techniques can have a positive effect on the financial performance of DT-SACCOs. These techniques can help to minimize potential losses and maximize returns on investments. Additionally, effective financial risk management can improve the overall stability and resilience of the SACCO, which can increase confidence among members and attract new deposits.

Tapiero (2004) defines financial risk management strategies as the strategic use of financial instruments to mitigate exposure to risks, namely credit and market risk, of a corporation, thereby generating economic value. Financial risk management encompasses the establishment of a suitable risk environment, the identification and quantification of the bank's risk exposure, the mitigation of risk exposure, the monitoring of risk, and the development of controls to safeguard the bank against financial hazards. The possibility that a borrower or debtor won't pay back a lender is known as credit risk. The ratio of bad loans to total loans is a measure of risk (Kiyai, 2018). One measure of a bank's liquidity is the proportion of its total assets to its liquid assets; this ratio indicates the extent to which the bank can withstand changes in the value of its assets as a result of credit financing and portfolio investments (Gallati, 2022).

According to Fritz-Morgenthal et al. (2022), a company's financial performance can be described as its ability to achieve specific financial goals. For the sake of shareholders and investors and the health of the economy as a whole, financial performance is paramount. An investment's return on investment (ROI) is comprehensive, and a strong company can increase ROI for investors over time (Fatihudin & Mochklas, 2018). Any business that wants to stay in business and grow must achieve financial success.

There are various methods used to evaluate financial performance, and they all need to be standardized. Indicators of financial performance (FP) include return on assets (ROA), number of employees, return on equity (ROE), and sales return (ROS). Return on assets and return on equity are the two most used measures. ROE analyzes the utilization of shareholder equity, whereas ROA evaluates a firm's financial performance by taking its total assets into account (Gadzo et al., 2019).

SACCOs in Kenya are categorised into two types: deposit taking and non-deposit taking. Deposit-taking SACCOs agree to engage in the process of depositing and withdrawing funds on a daily basis, similar to the operations of banks (Gitau, 2021). Not accepting deposits Typically, SACCOs function exclusively in the back office and have not acquired a licence from SASRA to expand their activities to include a front office.

The primary objectives of SACCOs are to provide credit and offer saving products to their members. However, these objectives are accompanied with financial risks, which necessitates effective management. Deficiency in financial risk management is the primary factor contributing to failures in SACCOs (Mugo et al., 2019). The earnings derived from investing in a business serve as the compensation for the risk undertaken by the owners of the

business. Effective implementation of financial risk management strategies can help SACCOs reduce their overall vulnerability to financial hazards. This enabled them to secure a competitive position in the industry (Odhiambo, 2019).

1.1 Statement of the Problem

Deposit-taking Savings and Credit Cooperative Organizations (DT-SACCOs) are involved in financial intermediation, benefiting 6.3% of Kenyans and relying on them by almost 60% of the Kenyan population (FinAccess, 2022). Notwithstanding this, 30% of the population lacks effective financial risk management strategies, as indicated by unpaid deductions by employer institutions or defaults by borrowers and inexperienced personnel (Tassew & Hailu, 2019).

Their susceptibility to de-licensing due to financial weaknesses exposes the 341 billion shillings' member funds to risk (Orichom & Omeke, 2020). Notwithstanding the government's allocation of funds towards a regulating body to guarantee compliance with rules and financial sustainability of DT-SACCOs, this problem persists. This is because members may experience a depreciation in the value of their diligently contributed funds due to the absence of safeguards for their deposits.

Consequently, this might lead to significant anxiety and diminished trust in the specific industry (Fin Access, 2022). There has been a major problem with financial risk among Kenyan SACCOs that accept deposits (Orichom & Omeke, 2020). An additional finding from Moody's 2019 study was that the worsening state of Kenya's financial sector was reflected in the increasing nonperforming loans (NPLs) among the country's banks and SACCOs. The focus has mainly been on banks, although SACCOs face increased credit risk.

Given the critical role that DT-SACCOs play in financial inclusion and intermediation, it is vital that we analyze the strategies they use to manage financial risk. Thus, it is essential to conduct research on how DT-SACCOs in Kenya are affected by risk management measures. Institutions like banks have their financial performance impacted by risk management strategies, according to research. Not only that, but different results have come from the various investigations.

The purpose of Ochieng's (2021) research was to examine deposit-taking SACCOs in Nairobi County, Kenya, to find out how their ROA was affected by financial risk management tactics. There is a negative correlation between ROA and credit risks, but no correlation between ROA and operational risks, according to the results. But the research could only look at Nairobi County.

Gitau (2021) looked into how dairy cooperatives in Kenya's Kisii, Nyamira, Bomet, and Kericho counties fared when faced with financial risk. The results showed that financial risk has a big impact on how well dairy cooperatives do. Financial risks and the performance of Kenyan commercial banks were the subject of Onsongo et al (2020) empirical study. Credit, and exchange rate risk were found to have a strong adverse relationship with performance. The increasing number of documented failures and financial losses by deposit-taking SACCOs over the years prompted this investigation. One factor that contributed to the collapse was credit risk.

Previous investigations have failed to fill in the obvious conceptual and contextual gaps, which prompted this inquiry. While this study did include credit risk, prior studies had operationalized financial risk management strategies differently, mostly ignoring them. Since most of the previous studies on this topic have been on commercial banks, we need to see if DT-SACCOs get the same treatment. There has to be a study that uses primary data to cover more ground as most previous research has used secondary data. The current investigation was based on these shortcomings.

1.2 Research Objective

To examine the effect of credit risk management techniques on financial performance of deposit taking SACCOs in Kenya

1.3 Research Hypotheses

H₀₁: Credit risk management techniques have no significant effect on financial performance of deposit taking SACCOs in Kenya.

II. LITERATURE REVIEW

2.1 Theoretical Review

2.1.1 Credit Risk Theory

Robert Merton initially proposed this hypothesis in 1974. It delineates the fundamental endeavors to quantify and control credit risk exposure. The borrower perceives default as an inherent put option that can be exercised when

the conditions are economically advantageous for the borrower to initiate default (Levine et al., 2000). The option-theoretic methodology described here can be applied to any borrower type and serves as the foundation for empirical default modeling. The calculation of credit loss estimates involves the integration of the borrower's likelihood of default with their loss given default or loss severity. Sparrow (2000) propose that the Merton default model offers a conceptual approach to effectively identify both loss components.

This study demonstrates that the credit risk theory provides support for the credit risk variable. There are primarily three quantitative approaches to credit risk analysis: the structural, reduced form, and incomplete information methods. The structural method was laid by Merton in 1974 when he created a model that used the firm's capital structure. In his model, if the company's value falls below a specific threshold at that instant, it will not be able to repay the loan by the specified time T . As a result, the default time is a discrete random variable that, if the corporation defaults, selects T and, else, goes to infinity. Corporation equity, then, is a contingent claim on the worth of the accumulated assets of the business.

This theory elucidates the commercial banks' comprehension of the credit risk idea, namely how loan defaulters' failure to repay their loans results in risk. Consequently, commercial banks should devise ways to facilitate loan recovery or provide a provision to address credit impairment for non-performing loans. An inherent constraint of the credit risk theory is its focus on the origins and probability of credit risk, without providing recommendations on how to proactively reduce or eliminate credit risk.

Given the crucial role that credit risk plays in the operations and financial stability of SACCOs, the theory is quite pertinent in this study. It establishes a structure for comprehending the possible financial losses that SACCOs may experience due to defaults, hence highlighting the need of implementing efficient credit risk management strategies. By applying this theory, the study examines the effectiveness of SACCOs in managing their credit risks and the overall impact on important financial performance metrics.

2.2 Empirical Review

2.2.1 Credit Risk Management Techniques and Financial Performance

Gitau (2021) examined the impact of CRM on the financial performance of dairy cooperatives in the Kenyan counties of Kisii, Nyamira, Bomet, and Kericho. A descriptive panel design was employed in this investigation, utilizing secondary data. The study focused on four dairy marketing cooperatives with a population of 1,245 registered dairy producers in December 2018. These cooperatives were chosen to serve as the independent variables in the study. The sample and secondary data were gathered over a ten-year period, from 2009 to 2018, using the census sampling method. Multiple panel regression models were used for additional analysis of the data that was acquired utilizing a supplementary data collection sheet. The evidence suggested that credit management significantly impacted ROI. Testing also verified that the components used to evaluate dairy marketing cooperatives' performance were statistically significant. There is a lack of information on other financial risk management strategies since this study only looked at credit risk management.

Otanga et al. (2020) investigated how CRM impacted DT-SACCOs' FP in Western Kenya. From a census of the 19 DT-SACCOs that took place between 2013 and 2017, 95 data points were selected for this study using a correlational research approach. Purposive sampling was used to select interviewees. Secondary data extracted from financial records was used in the study. Researchers used hierarchical panel data regression to analyze the data. Financial performance is improved when the nonperforming loan ratio is reduced, as CRM has a statistically significant negative effect on FP. This research argues that DTSACCOs in Western Kenya rely heavily on corporate risk management. To improve their financial performance, SACCOs should invest in credit risk management measures, according to the report. The focus was on SACCOs in Western Kenya, therefore the findings might not apply to other SACCOs.

Munangi and Sibindi (2020) conducted an empirical study to investigate the impact of credit risk on the financial performance of South African institutions from 2008 to 2018. In order to quantify credit risk, the study employed growth, capital adequacy, size, non-performing loans, and bank leverage. The financial success of South African banks was measured by ROE and ROA. Credit risk and financial performance were found to have a negative link, according to the study's overall conclusions. In order to reduce the frequency of non-performing loans, the study recommended implementing strict credit standards. To further reduce the possibility of bank collapse caused by credit risk, the report recommended that regulators step up their oversight of financial institutions to ensure they adequately manage their credit risk. South Africa, where the current study was conducted, has a very different economic and social environment from Kenya, where the current study was located.

The impact of customer relationship management strategies on the bottom lines of Mahila cooperative banks in India's Kalaburagi area was investigated by Dayasagar (2019). We set out to examine how women-run cooperative banks fared financially after implementing a system for identifying, analyzing, monitoring, and reducing credit risk.

According to the results, performance was greatly enhanced by credit analysis, mitigation, and identification. As a result, women-run cooperative banks should implement credit monitoring systems and use more stringent credit analysis methodologies. Compared to Kenya, where the current study was conducted, India's economic and social environment is very different.

Moslehpour et al. (2022) investigated how credit risk affected the profitability of deposit banks in Vietnam. Nonperforming loans (NPLs) were used as a measure of credit risk, whereas ROA and ROE were used as measures of financial performance. Between 2005 and 2017, twenty-six commercial banks in Vietnam were the subjects of the study. The study relies on secondary data culled from the Vietnam Banks Association's statistical reports. Research showed that ROE is inversely related to credit risk. Additionally, the data showed that ROA is negatively correlated with credit risk.

The current study was conducted in Kenya, although the inquiry was conducted in Vietnam, which has a very different social and economic backdrop.

2.6 Conceptual Framework

The objective of this study was to evaluate the correlation between financial risk management strategies and the financial performance of deposit accepting Savings and Credit Cooperative Operations (SACCOs) in Kenya. This study examined the relationship between financial risk management strategies as independent factors and financial performance as the dependent variable. Financial risk management techniques encompassed credit risk management. Financial performance was assessed based on the proportion of non-performing loans (NPLs), frequency of external liquidity borrowings, foreign exchange losses and gains, as well as instances of fraud and embezzlement. Depicted in Figure 1 is the correlation among these variables.

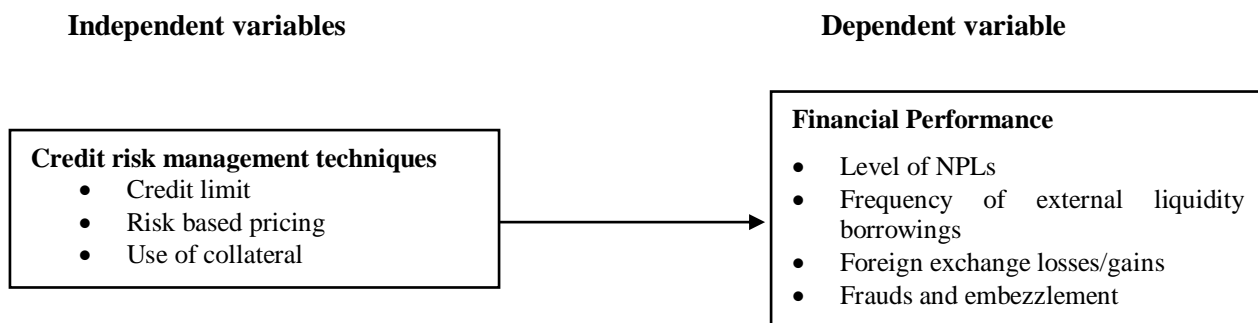

Figure 1
Conceptual Framework
(Author, 2023)

III. METHODOLOGY

3.1 Study Area

The study focused on all the 175 DT SACCOs in Kenya as it provides a comprehensive and holistic view of the effects of financial risk management techniques on their financial performance. These SACCOs, spread across the diverse geographical terrains of Kenya – from the coastal regions of Mombasa, the agricultural highlands of Rift Valley, to the arid areas of the North – present a mosaic of economic activities and challenges. This nationwide approach ensures that the study captures a rich array of financial risk management practices employed by SACCOs, dictated by their unique regional economic activities, member demographics, and operational challenges.

3.2 Research Design

This research employed a descriptive survey approach to investigate the impact of financial risk management strategies on the financial performance of DT-SACCOs in Kenya (Khan, 2018). The survey design was appropriate as the researcher was knowledgeable about the observed phenomena but also interested in understanding the nature of the relationships between the variables employed in the study. Furthermore, the chosen design was suitable as it enables the researcher to carefully compare the research findings and address the concerns of what, where, and how (Cooper & Schindler, 2017).

3.3 Target Population

The target population refers to a specific observation of interest within a larger set, such as clusters or events, as demonstrated by Burns & Burns (2018). The target population were all the DT SACCOs in Kenya. As of December 2022, Kenya has a total of 175 operational registered DT-SACCOs (Moody Investor Services, 2023). The participants consisted of the risk managers from each DT SACCO.

3.4 Sample Size and Sampling Procedure

This research exercised a census sampling which enabled all the target population companies to be utilized in analysis. The study population was small (175) therefore this study was a census. Furthermore, the accuracy challenges brought by sampling are solved through census (Khan, 2018). The respondents were the risk managers in each deposit taking SACCO. The list of SACCOs and the respective respondents was compiled in the table below.

Table 1:

<i>Sample Size</i>		
SACCO No.	SACCO Name	Respondent
	175 SACCOs	Risk Managers

3.5 Data Collection Instruments and Procedures

Data collecting instruments are quantitative tools employed to gather data in a research investigation. The collection of primary data was undertaken in order to accomplish the established study goals. Data collection was conducted by administering a well-designed questionnaire. The selection of a structured questionnaire was based on the experiment's quantitative methodology, which involves the analysis of numerical data. Quantitative categorical data can be effectively obtained using structured surveys. In addition, the data subjects are measured on a 5-point Likert scale and must be clear and unambiguous to minimize potential confusion among the respondents. The survey included five-point Likert-type scales, with values ranging from one (representing the lowest point) to five (presenting the greatest point). The individual responding held the position of operations manager in each SACCO.

Drop and pick later (physical distribution) was employed, and online based questionnaire in distributing questionnaires to the heads of risk in the 175 SACCOs who filled the questionnaires. For the questionnaires distributed in person, the filled questionnaires were collected immediately while those respondents that asked for extra time to fill the questionnaire were granted. For the online-based questionnaire, the researcher sought consent of the respondents, requested for the email address before sharing the link that contained the online based questionnaire.

3.6 Reliability and Validity

Prior to the actual distribution of the questionnaire to the participants, it underwent a pretest to ensure its competence as a tool. Pretesting of the questionnaire was conducted in 18 DT- SACCOs in Nairobi County, which represents 10% of the target population. Cooper and Schindler (2017) assert that a 10% sample of the target population is sufficient for conducting pilot testing. All 10 SACCOs were excluded from the final study. A research assistant was hired by the researcher to assist with the administration of the questionnaire. In instances when respondents could not be contacted through Google form, the assistant would retrieve and dispatch the questionnaire at a later time. The participants assisted in determining the required time for completing the surveys and pinpointed any mistakes that need to be rectified prior to distributing them to the intended recipients. In order to guarantee a substantial rate of responding, participants were guaranteed both secrecy and anonymity.

3.7 Data Processing and Analysis

Data analysis, as defined by Cooper and Schindler (2017), is the systematic procedure of organizing, structuring, and attributing significance to a vast volume of data. Data analysis refers to the process of transforming unprocessed data into practical information, usually presented as a published analytical written work, with the aim of maximizing the statistical results (Khan, 2018). The data was systematically arranged and condensed using descriptive statistics. The statistical measures of mean, variance, standard deviation, and graphical representations were employed for this purpose. Furthermore, the data was analyzed using inferential statistics, including the Pearson correlation, analysis of variances (ANOVA), and the multiple linear regression model. The data for this study was examined using a multiple linear regression model and correlation analysis methodology. The research hypotheses were tested using regression analysis to establish the relationship between financial risk management strategies and financial performance. Both tables and figures were employed to display the findings of the investigation. The data analysis in this study was conducted using SPSS software version 27.

The regression model below was applied:



$Y = \alpha + \beta X_1 + \varepsilon$ Model 1
 Where: Y = Financial performance
 α = y regression intercept.
 β_1 = regression slope
 X_1 = Credit risk management techniques
 ε = error term

3.8 Tests of Regression Assumptions

The following tests were run in order to test and find any kind of transgression to the regression assumptions before the data was analyzed.

3.8.1 Multi-collinearity

Multicollinearity is defined as situations where the independent variables are greatly related. Where two or more independent variables are related, it leads to collapse of the regression model since both variables must be dropped from the model (Cooper & Schindler, 2017). This research adopted the Variance Inflation Factor (VIF) to establish the multicollinearity.

Where multicollinearity is present in a set of data, the confidence interval for coefficients are usually very wide and the t-statistics are usually very small. The presence of multicollinearity between predictor variables can adversely affect the regression results of a study. A common understanding is that the VIF should be range 1-10. VIF of more than 10 indicates that there is high correlation.

3.8.2 Normality Test

To assess normality, Kolmogorov- Smirnov test was used. The justification for using the K-S test to measure normality was based on its ability to detect any significant differences between the empirical cumulative distribution function of the sample and the theoretical cumulative distribution function of the normal distribution. The K-S test can also be used for both small and large sample sizes. A p value greater than 0.05 was interpreted to mean that the data was normally distributed.

3.8.3 Heteroscedasticity Test

The assumptions of homogeneousness of variance is the supposition of the predictor samples t-test and Analysis of Variance (ANOVA) asserting that all assessment groups have the same group. The independent samples t-test and ANOVA use the *t* and *F* statistics correspondingly, which are usually sensitive to violation of the assumptions provided the unit amounts are equivalent (Cooper & Schindler, 2017). If the p-value of the test is less than the chosen significance level, the assumption of equal variances is rejected.

In the linear regression model, it is assumed that the error term exhibits homoscedasticity, meaning that of constant variance. The principle of equal variance of errors across all levels of the predictor (independent) variables, as proposed by Khan (2018), is observed. Therefore, it is presumed that the mistakes are distributed uniformly or consistently throughout the variables of the study. The presence of heteroscedasticity in the data indicates that the error variance is not constant, which can result in misrepresentation of results that undermine the overall investigation and numerical control of the analysis. This phenomenon gives rise to inaccurate and prejudiced outcomes. This study employed the Breusch-Pagan test to examine the homoscedasticity of the residuals.

IV. FINDINGS & DISCUSSION

4.1 Response Rate

The researcher distributed 175 questionnaires to the respective heads of risk of all 175 DT SACCOs in Kenya that were included in the study. A total of 136 out of the 175 questionnaires distributed were successfully completed, filled out, and returned, resulting in a response rate of 77.7%. According to Cooper and Schindler (2017), a study that attains a response rate of 70% should be regarded as outstanding for the purpose of data analysis and inference. The results of the investigation are presented in table 1 below.

Table 1*Response Rate*

Response Rate	Frequency	Percentage
Returned	136	77.7
Unreturned	39	22.3
Total	175	100

The analysis of Table 1 revealed that the study attained a response rate of 77.7%. Consequently, the data gathered for the study was deemed suitable for analysis, interpretation, and conclusion.

4.2 Demographic Information

The objective of this study was to explore the overall characteristics of the participants included in the research. The demographic variables examined in this study included gender, age, educational attainment, and tenure in the SACCO. The findings are presented in Table 2.

Table 2*Demographic Analysis*

Gender	Frequency	Percentage
Male	71	52.2%
Female	65	47.8%
Total	136	100%
Age	Frequency	Percentage
21-30 years	7	5.1%
31-40 years	47	34.6%
41-50 years	61	44.9%
Over 50 years	21	15.4%
Total	136	100%
Education Level	Frequency	Percentage
Diploma	11	8.1%
Degree	81	59.6%
Masters	43	31.6%
PhD	1	0.7%
Total	136	100%
No. of years in the SACCO	Frequency	Percentage
Less than 1 year	8	5.9%
1-3 years	42	30.9%
4-7 years	65	47.8%
8 years and above	21	15.4%
Total	136	100%

The study reveals a modest gender imbalance, with male respondents making up 52.2% of the sample and female respondents accounting for 47.8%. The observed distribution of gender within the studied SACCOs demonstrates a rather equitable representation, so indicating a wide range of viewpoints and experiences that contribute to the study.

With regards to age demographics, 34.6% of respondents are between 31 and 40 years old, while 44.9% are between 41 and 50 years old. Furthermore, 15.4% of the participants are aged 50 years or older, whilst a lesser percentage, 5.1%, fall between the age range of 21 to 30 years. The observed distribution indicates that the survey encompasses a substantial spectrum of experience levels and viewpoints, with a notable proportion of participants almost certainly having substantial professional expertise.

With regards to educational attainment, the data reveals a wide range of educational backgrounds among the respondents. A significant majority, accounting for 59.6%, possess a bachelor's degree, while 31.6% have achieved a master's university degree. Furthermore, 8.1% of the population carry a diploma, while a negligible fraction, 0.7%, have a PhD. The observed distribution highlights the need of having highly educated personnel in the SACCO business. A considerable number of respondents possess advanced education credentials, which could enhance their comprehension of financial risk management principles.



In terms of tenure within the SACCOs, the data demonstrates a diverse range of experience levels across the participants. A significant proportion, comprising 47.8%, have been affiliated with their individual SACCOs for a period of 4 to 7 years, while 30.9% have been with them for 1 to 3 years. Furthermore, 15.4% of the participants have a position of 8 years or more, and a lesser percentage, 5.9%, have less than 1 year of professional experience. The composition of this distribution encompasses both those who are new to the SACCO sector and experienced professionals, therefore offering a broad viewpoint on the subject issue.

This demographic research offers significant insights into the makeup of the population of respondents, emphasizing the variety in gender, age, educational backgrounds, and length of service in deposit-taking SACCOs in Kenya. The aforementioned observations contribute to the enrichment of the study's results and bolster the legitimacy and pertinence of its conclusions concerning the influence of financial risk management strategies on the financial performance of SACCOs.

4.3 Descriptive Statistics

Analysis and interpretation of the mean and standard deviation of the data using descriptive statistics enabled the researcher to have a comprehensive grasp of the distribution and trends within the dataset. Furthermore, they established a basis for subsequent inferential statistical interpretations and decision-making in the study process.

4.3.1 Credit Risk Management Techniques

Table 3 presents descriptive statistics pertaining to various credit risk management techniques employed by DT SACCOs in Kenya. The analysis offers insights into the mean scores and standard deviations associated with each statement, shedding light on the perceived effectiveness and prevalence of these techniques within the surveyed SACCOs.

Table 3
Descriptive Statistics for Credit Risk Management Techniques

Statements	N	Mean	Std. Dev.
There are enough staff members who deal with credit limiting to the customers from the executive board	136	3.24	1.16
The Credit Risk management team is counterpart and play important roles in company decisions.	136	3.76	1.04
At least one of the nonexecutive directors on the SACCO's risk committee has banking experience	136	2.70	1.17
In the SACCO collateral management practices are common.	136	2.45	1.13
Risk based pricing policy of implementing varying Customers' rate of interest and loans are practiced.	136	3.07	1.15
The SACCO analyses customer credit history regularly	136	2.57	0.98
Overall mean Score	136	2.97	0.79

The first statement indicates that, on average, respondents scored 3.24, with a standard deviation of 1.16, in response to the adequacy of staff members dealing with credit limiting from the executive board. This suggests a moderate level of agreement among respondents regarding the availability of staff resources dedicated to managing credit limitations, albeit with some variability in perceptions.

Regarding the importance of the Credit Risk management team in company decisions, respondents provided an average score of 3.76, with a standard deviation of 1.04. This indicates a relatively high level of agreement among respondents regarding the significance of the Credit Risk management team in influencing organizational decisions, with relatively low variability in perceptions.

The third statement concerning the banking experience of nonexecutive directors on the SACCO's risk committee yielded an average score of 2.70, with a standard deviation of 1.17. This suggests a moderate level of agreement among respondents regarding the presence of banking experience among nonexecutive directors, albeit with considerable variability in perceptions. In terms of collateral management practices within SACCOs, respondents provided an average score of 2.45, with a standard deviation of 1.13. This indicates a relatively low level of agreement among respondents regarding the prevalence of collateral management practices, with notable variability in perceptions.

Regarding the implementation of risk-based pricing policies, respondents scored an average of 3.07, with a SD of 1.15. This suggests a moderate level of agreement among respondents regarding the adoption of risk-based pricing policies, with some variability in perceptions. The analysis also indicates that respondents, on average, scored

2.57 with a standard deviation of 0.98 in terms of the SACCO's regular analysis of customer credit history. This suggests a moderate level of agreement among respondents regarding the frequency of customer credit history analysis, with some variability in perceptions.

Overall, the descriptive statistics reveal a mixed perception among respondents regarding the effectiveness and prevalence of credit risk management techniques within deposit-taking SACCOs in Kenya. While certain techniques such as the importance of the Credit Risk management team in decision-making garnered relatively high levels of agreement, others such as the presence of banking experience among non-executive directors exhibited more variability in perceptions.

4.3.2 Financial Performance

Table 4 presents descriptive statistics regarding the financial performance indicators of deposit-taking SACCOs (DT-SACCOs) in Kenya. This analysis offers insights into the mean scores and standard deviations associated with each statement, providing an understanding of the perceived financial performance of the surveyed SACCOs.

Table 4
Descriptive Statistics for Financial Performance

Statements	N	Mean	Std. Dev.
The level of NPLs have been decreasing over the years	136	4.01	0.86
The DT-SACCO is efficient in collecting overdue loans	136	3.97	0.85
Frequency of external liquidity borrowings has been decreasing	136	3.85	0.92
The SACCO maintains sufficient liquidity	136	3.94	0.86
Foreign exchange losses have been declining over the years	136	3.56	0.96
The SACCO consistently manages to make foreign exchange gains	136	3.76	0.93
Cases of fraud and embezzlement have been on a decline over the years	136	3.74	1.01
The DT-SACCO has been able to reduce incidences of fraud	136	4.05	0.75
Overall Mean Score	136	3.86	0.68

The first statement addresses the trend in non-performing loans (NPLs), with respondents providing an average score of 4.01 and a standard deviation of 0.86. This indicates a relatively high level of agreement among respondents regarding the decreasing trend of NPLs over the years, with moderate variability in perceptions, suggesting that DT-SACCOs have been successful in managing and reducing their NPL levels.

Similarly, respondents provided an average score of 3.97 with a standard deviation of 0.85 in response to the efficiency of DT-SACCOs in collecting overdue loans. This suggests a relatively high level of agreement among respondents regarding the effectiveness of DT-SACCOs in collecting overdue loans, with moderate variability in perceptions, indicating that these SACCOs have robust mechanisms in place for loan recovery.

Regarding the frequency of external liquidity borrowings, respondents scored an average of 3.85 with a standard deviation of 0.92. This indicates a moderate level of agreement among respondents regarding the decreasing frequency of external liquidity borrowings, with notable variability in perceptions, suggesting that DT-SACCOs are gradually reducing their reliance on external borrowings to maintain liquidity. In terms of maintaining sufficient liquidity, respondents provided an average score of 3.94 with a standard deviation of 0.86. This indicates a relatively high level of agreement among respondents regarding the sufficiency of liquidity maintained by DT-SACCOs, with moderate variability in perceptions, suggesting that these SACCOs are effectively managing their liquidity positions.

Respondents scored an average of 3.56 with a standard deviation of 0.96 in response to the declining trend of foreign exchange losses over the years. This indicates a moderate level of agreement among respondents regarding the reduction of foreign exchange losses, with notable variability in perceptions, suggesting that DT-SACCOs are implementing measures to mitigate foreign exchange risks. Similarly, the statement addressing the consistent management of foreign exchange gains yielded an average score of 3.76 with a standard deviation of 0.93. This indicates a moderate level of agreement among respondents regarding the consistent management of foreign exchange gains, with moderate variability in perceptions, suggesting that DT-SACCOs are effectively managing their foreign exchange exposures to capitalize on gains.

Regarding the incidence of fraud and embezzlement, respondents provided an average score of 3.74 with a standard deviation of 1.01. This indicates a moderate level of agreement among respondents regarding the declining trend of fraud and embezzlement cases, with considerable variability in perceptions, suggesting that DT-SACCOs are implementing measures to curb fraudulent activities. Finally, the statement concerning the reduction of fraud incidences yielded an average score of 4.05 with a standard deviation of 0.75. This indicates a relatively high level of



agreement among respondents regarding the successful reduction of fraud incidences, with low variability in perceptions, suggesting that DT-SACCOs have implemented effective controls to mitigate fraud risks.

Overall, the descriptive statistics reveal a generally positive perception among respondents regarding the financial performance of DT SACCOs in Kenya. Indicators such as decreasing NPLs, efficient loan collection, reduced reliance on external borrowings, sufficient liquidity management, declining foreign exchange losses, consistent management of foreign exchange gains, and decreasing incidences of fraud and embezzlement are perceived to contribute to the overall financial health of DT-SACCOs. However, there is some variability in perceptions, indicating potential areas for further improvement and examination to sustain and enhance financial performance.

4.4 Diagnostic Tests

The study performed the following tests: normality test, multicollinearity test, and heteroscedasticity test.

4.4.1 Normality Test

A normality test must be performed in order to determine whether the data for regression analysis is regularly distributed. Deviation from normal distribution of data can lead to distortion of the results in subsequent analysis. An initial analysis was conducted to determine if the data conforms to a normal distribution. An evaluation of the normality of the score distribution was conducted using the Kolmogorov-Smirnov test. The findings of the normalcy test are presented in Table 5

Table 5

Kolmogorov-Smirnov Test for Normality

Variable	Kolmogorov-Smirnov ^a		
	Statistic	df	Sig.
Credit risk management techniques	.931	17	.151
Financial performance of deposit-taking SACCOs	.796	17	.261

The results in Table 5 show that when the test statistic is greater than 0.05, it suggests that the data follows a normal distribution as recommended by Zhongming et al. (2019). In Table 5, the results of the Kolmogorov-Smirnov test are presented. The obtained normality test results in the table above suggest that the data pertaining to each variable follows a normal distribution, as the significance value in all instances exceeds 0.05. Consequently, the data is appropriate for subjecting to correlation and regression analysis.

4.4.2 Test for Multicollinearity

Multicollinearity manifests when two or more predictors in a regression model exhibit a moderate or high correlation, therefore constraining the ability to make research findings. Coefficient estimates for individual predictors become unstable when multicollinearity causes standard errors and confidence intervals to inflate. To assess multicollinearity, this study used the Variance Inflation Factor (VIF). If the VIF factor's value is 1, it means that no two predictor variables are associated with each other. A VIF parameter of 5 suggests the presence of multicollinearity, while a value of 10 indicates substantial multicollinearity, as illustrated in Table 6.

Table 6

Variance Inflation Factor

Variable	VIF	1/VIF
Credit risk management techniques	1.072	0.933
Mean	1.559	

The findings were displayed in Table 6 An analysis of the variance inflation factor was performed to assess the presence of multicollinearity among the predictors. A value below 10 is considered acceptable. The credit risk management strategies had a V.I.F value of 1.072, which is below 10, indicating the absence of multicollinear correlation.

4.4.3 Heteroscedasticity Test

The term heteroscedasticity describes a situation when the variability of a variable is not consistent throughout the range of values of a second variable that predicts it. As the independent variable grows, the variability of the



dependent variable either widens or narrows, resulting in homoscedasticity within cross-sectional units. Nevertheless, the spread of its variation may vary among units, which is referred to as group-wise heteroscedasticity.

Table 7
Heteroscedasticity Results

Test Statistic	P-Value
7.87	0.0510
H ₀ : Constant Variance	

The Breusch-Pagan test assesses the degree of variability demonstrated by the residuals of the model. The null hypothesis posited that the variance of the data remains constant, while the alternative hypothesis considered that the variance of the data is not constant. The data shown in Table 7 does not provide sufficient evidence to reject the null hypothesis of Homoscedastic error terms. This is evident from the p-value of 0.0510, which above the significance level of 0.05, therefore suggesting the absence of Heteroscedasticity. The results of this test indicate that the data exhibits homoscedasticity.

4.5 Inferential Statistics

This section presents the findings for both correlation and regression analysis.

4.5.1 Correlation Analysis

Table 8 displays the correlation between the independent factor (credit risk management techniques) and the financial performance of deposit-taking SACCOs, which is the dependent variable. The Pearson correlation coefficients quantify the magnitude and orientation of the linear association between these variables, while the significance level (Sig. 2-tailed) offers details on the statistical importance of these relationships. Statistically significant positive connection ($r = 0.711$, $p < 0.05$) exists between credit risk management strategies and the financial success of deposit-taking SACCOs. Consequently, when deposit-taking SACCOs intensify their credit risk management strategies, they are more likely to achieve superior levels of financial performance. These findings are consistent with the research conducted by Gitau (2021) on dairy cooperatives in Kenya, which demonstrated a statistically significant and positive effect of credit management on the return on investment. This suggests that efficient management of credit risks has a beneficial influence on the financial performance of organizations.

Table 8
Correlation Results

		Financial performance	Credit risk management techniques
Financial performance	Pearson Correlation	1	
	Sig. (2-tailed)		
Credit risk management techniques	Pearson Correlation	.711**	1
	Sig. (2-tailed)	.000	

4.5.2 Regression Analysis

The objective of the regression study was to ascertain the impact of the independent factors on the dependent variable, which is the financial performance of deposit-taking SACCOs. The modeling summary, ANOVA, and coefficients tables display the results of the analysis. The model summary quantifies the extent to which the independent variables included in the model account for the variability in the dependent variable. The ANOVA table assesses the statistical significance of the model fit in predicting the dependent variable, whereas the coefficient table measures the quantitative relationship between the variables. The present study presents the results in the tables provided below.

Table 9
Model Summary

Model	R	R Square	Adjusted R Square	Std. Error of the Estimate	Durbin-Watson
1	.965 ^a	.931	.928	.226045	2.286

a. Predictors: (Constant) Credit risk management techniques

b. Dependent Variable: Financial performance



Table 9 presents a concise overview of the robustness and capacity to make accurate predictions of the regression model. A very strong linear relationship between the predictor Credit risk management techniques and the dependent variable, financial performance of deposit-taking SACCOs, is indicated by the R-value of 0.965. The coefficient of determination (R Square) is 0.931, suggesting that almost 93.1% of the variation in the financial performance of DT SACCOs can be accounted for by the predictor variable included in the model.

Table 10
ANOVA

Model		Sum of Squares	df	Mean Square	F	Sig.
1	Regression	89.699	4	22.425	438.870	.000 ^b
	Residual	6.694	131	.051		
	Total	96.392	135			

a. Dependent Variable: Financial performance

b. Predictors: (Constant) Credit risk management techniques

Table 10 examines the hypothesis that the regression model provides a considerably superior prediction of the dependent variable (financial performance of deposit-taking SACCOs) compared to a model without any predictors. The F-statistic, which quantifies the extent to which the model enhances the prediction of the result compared to a model without any predictors, is reported as 438.870. The remarkably low significance value (Sig.) of .000, which falls below the standard significance level (0.05), provides compelling evidence that the regression model is more suitable for fitting the data compared to the intercept-only model. Fundamentally, the factors included in the regression model make a substantial contribution to elucidating the fluctuations in the financial performance of DT SACCOs, and the model has statistical significance.

Table 11
Model Coefficients

Model		Unstandardized Coefficients		Standardized Coefficients	t	Sig.
		B	Std. Error	Beta		
1	(Constant)	1.143	.174		6.559	.000
	Credit risk management techniques	.238	.046	.317	5.185	.000

a. Dependent Variable: Financial performance

From the Table 11 the following model has been developed;

$$Y = 1.143 + 0.238X_1$$

Where:

Y = financial performance of deposit-taking SACCOs

X₁ = credit risk management techniques

4.6 Discussion

4.6.1 Credit Risk Management Techniques and Financial Performance

The financial performance of DT SACCOs in Kenya is positively correlated with credit risk management measures, according to regression analysis ($\beta = 0.238$, $t = 5.185$, $p < 0.05$). These results show that deposit-taking SACCOs' overall financial performance improves once they apply measures for managing credit risk. For deposit-taking SACCOs, a coefficient of 0.238 indicates that their expected financial performance should increase by 0.238 units for every unit increase in credit risk management measures.

Previous research has investigated the relationship between credit risk management (CRM) and financial performance (FP) in different contexts, and the empirical findings of this study are in line with those of Gitau (2021), Otanga et al. (2020), and Munangi and Sibindi (2020). Gitau found a favorable and statistically significant relationship between credit management and ROI in his study of Kenyan dairy cooperatives. This indicates that these operations' financial performance is improved by implementing effective credit risk management strategies. Otanga et al. (2020) found that deposit-taking SACCOs in Western Kenya's financial performance is greatly affected by credit risk management. According to their findings, improved financial results are the result of a lower non-performing loan ratio, which is attained via effective management of credit risk.

In addition, Munangi and Sibindi's (2020) empirical research on South African banks adds to the growing body of evidence showing that credit risk significantly affects financial performance, although in a negative way.

Despite the study's focus on banks, its findings highlight the importance of tightening credit regulations and enhancing regulatory monitoring to safeguard financial performance and decrease credit risk. All things considered, these findings highlight how crucial credit risk management tactics are for determining the financial success of many types of financial companies, including SACCOs.

V. CONCLUSION & RECOMMENDATIONS

5.1 Conclusions

The study aimed to assess the effect of credit risk management techniques on financial performance. The findings indicate that effective credit risk management practices, such as risk-based pricing policies and regular analysis of customer credit histories, significantly contribute to improved financial performance within SACCOs. These practices help mitigate the risk of non-performing loans and enhance the overall stability of SACCOs' loan portfolios, leading to enhanced financial performance.

5.2 Recommendations

SACCOs should focus on enhancing their credit risk management frameworks. This can be achieved by implementing robust credit risk assessment mechanisms, such as comprehensive credit scoring models and regular analysis of customer credit histories. Strengthening collateral management practices and implementing risk-based pricing policies aligned with the level of credit risk associated with borrowers can further mitigate potential credit risks. Moreover, continuous training and capacity building programs for staff involved in credit risk management are essential to ensure the effective implementation of credit risk mitigation strategies.

REFERENCES

- Bruett, T. (2011). The Latest Frontiers for Financial Inclusion: New York: *Community Development Investment Review* 27(33):111-118.
- Burns, R. B. & Burns, R. A. (2018). *Business Research Methods and Statistics using SPSS*. London. Sage Publications Limited.
- Cooper, D., & Schindler, S. (2017). *Business research methods*. McGraw-Hill Irwin.
- Dayasagar, I. (2019). Impact of credit risk management techniques on financial performance of Mahila cooperative banks in Kalaburagi district. *Seshadripuram. Journal of Sciences*, 8(9), 432-437
- Fatihudin, N. & Mochklas, M. (2018). Inefficient markets, anomalies, and investor behavior: A Literature Review. *International Journal of Economics, Business and Accounting Research (IJEBAR)*, 5(2), 67-69.
- Fin Access. (2021). *Financial inclusion in Kenya*. International Monetary Fund.
- Fritz-Morgenthal, S., Hein, B., & Papenbrock, J. (2022). Financial risk management and explainable, trustworthy, responsible AI. *Frontiers in artificial intelligence*, 5, 779799.
- Gadzo, S., Kporgtorgbi, H., & Gatsi, J. (2019). Credit risk and operational risk on financial performance of universal banks in Ghana: A partial least squared structural equation model (PLS SEM) approach, *Cogent Economics & Finance*, 7(1), 1-11.
- Gallati, R. R. (2022). *Risk management and capital adequacy*. McGraw-Hill. Irwin.
- Gitau, B. (2021). Influence of credit management on financial performance of dairy marketing cooperatives in Kenya. *International Journal of Accounting, Finance and Risk Management*, 6(1), 10-15.
- Irusa, C. (2018). *The Effect of Credit Risk Management Techniques Policy on Financial Performance of Commercial Banks in Kenya* (MBA Research Project, University of Nairobi).
- Khan, J. A. (2018). *Research Methodology*. New Delhi. APH Publishing Corporation
- Kiyai, E. (2018). *Effect of Credit Risk Management Techniques on the Financial Performance of the Commercial Banks Listed at the Nairobi Securities Exchange*, Unpublished MBA Project, University of Nairobi
- Lagat, F., Mugo, F. & Otuya, R. (2013). Effect of Credit risk management techniques Practices on Lending Portfolio among Savings and Credit Cooperatives in Kenya. *European Journal of Business and Management* 5(19); 93-105.
- Levine, B. Loayza G. & Beck, H (2000). Financial Intermediation and Financial performance: Causality and Causes, *Journal of monetary economics* 46, 31-77.
- Moody Investor Services. (2023). *Default Trends and Rating Transitions in Africa*. Moody Investor Services, June 2022, Free Press.



- Moslehpour, M., Al-Fadly, A., Ehsanullah, S., Chong, K. W., Xuyen, N. T. M., & Tan, L. P. (2022). Assessing Financial Risk Spillover and Panic Impact of Covid-19 on European and Vietnam Stock market. *Environmental Science and Pollution Research*, 8(6), 1-15.
- Mugo, D. M., Muathe, S., & Waithaka, S. T. (2019). Performance analysis of debit card services on deposit-taking SACCOs' financial performance: A Case of Kenya. *Journal of International Business*, 11(2), 23-44.
- Munangi, E., & Sibindi, A. B. (2020). An empirical analysis of the impact of credit risk on the financial performance of South African banks. *Academy of Accounting and Financial Studies Journal*, 24(3), 67-70.
- Ochieng, K. O. (2021). *Effect of Financial risk management techniques Practices on Financial Performance of Deposit Taking Savings and Credit Cooperatives in Nairobi County, Kenya* (Doctoral dissertation, University of Nairobi).
- Odhiambo, S. P. O. (2019). Determinants of financial performance of savings and credit cooperative societies in Nakuru town, Kenya. *Reviewed Journal International of Business Management*, 1(1), 42-53.
- Onsongo, S. K., Muathe, S. M., & Mwangi, L. W. (2020). Financial Risk and Financial Performance: Evidence and Insights from Commercial and Services Listed Companies in Nairobi Securities Exchange, Kenya. *International Journal of Financial Studies*.8(4), 23-26.
- Orichom, G., & Omeke, M. (2020). Capital structure, credit risk management techniques and financial performance of micro finance institutions in Uganda. *Journal of Economics and International Finance*, 13(1), 24-31.
- Otanga, K., Mule, R., & Momanyi, G. (2020). Effect of credit risk management techniques on financial performance of Deposit taking savings and credit cooperatives societies in Western Kenya. *IOSR Journal of Business and Management*, 22(9), 30-35.
- Sparrow, A. (2000). *A theoretical framework for operational risk management and opportunity realisation* (No. 00/10). New Zealand Treasury Working Paper.
- Tapiero, C. S. (2004). *Risk and financial management: mathematical and computational methods*. John Wiley & Sons.
- Tassew, A. W., & Hailu, A. A. (2019). The effect of risk management on financial performance of commercial banks in Ethiopia. *Financial Studies*, 23(1 (83)), 25-38.
- World Bank. (2007). *The Little Data Book on Financial Inclusion*. Washington DC 20433: World Bank.
- Zhongming, T., Frimpong, S., & Guoping, D. (2019). Impact of Financial Risk Indicators on Banks' Performance in Ghana. *Business and Economic Research*, 9(4), 45-48.