

**EFFECTS OF CONVERGENCE INSUFFICIENCY VISION THERAPIES ON
ACCOMMODATION AMONG SCHOOL-GOING CHILDREN ATTENDING
MASINDE MULIRO UNIVERSITY ACADEMIC VISION CENTRE, KENYA**

Andrew Wekesa

**A Thesis Submitted in Fulfilment of the Requirements for the Degree of Master
of Science in Optometry and Vision Science at Masinde Muliro University of
Science and Technology**

December 2020

DECLARATION

This thesis is my original work prepared with no other than the indicated sources and support, and it has not been presented elsewhere for a degree or any other award.

Signature:

Date:

Andrew Wekesa

HOV/G/01-55815/2016

CERTIFICATION

The undersigned certify that they have read and as a result of this recommend for acceptance of Masinde Muliro University of Science and Technology a thesis entitled *'Effects of Convergence Insufficiency Vision Therapies on Accommodation among school-going Children attending Masinde Muliro University Academic Vision Centre, Kenya.'*

Signature 

Date:

Prof. Khathutshelo Percy Mashige, PhD

University of KwaZulu-Natal, South Africa

Signature

Date:

Maximilla Wanzala, Dr.

Masinde Muliro University of Science and Technology, Kenya.

COPYRIGHT

This thesis is copyright materials protected under the Berne Convention, the Copyright Act 1999, and other international and national enactments on that behalf, on intellectual property. It may not be reproduced by any means in full or in part except for short extracts in fair dealing so for research or private study, critical scholarly review or discourse with acknowledgment, with written permission from the Dean School of Graduate Studies on behalf of the author/s and Masinde Muliro University of Science and Technology.

DEDICATION

I dedicate this dissertation to my wife, Grace, children, Neema, Oscar, and Isaac, for encouragement and support.

ACKNOWLEDGEMENT

I take this opportunity to sincerely appreciate Prof Khathutshelo Percy Mashige and Dr. Maximilla Wanzala for their supervision and guidance of this dissertation. I extend my acknowledgment to the departmental lectures who contributed immensely to structuring the research idea, my colleagues for their advice during a personal consultation, especially Mr. Alfred Ragen, with whom we share similar interests in optometry. Finally, I extend my sincere appreciation to my parent's Dr. Raymond Wekesa and Dr. Imelda Nafula.

ABSTRACT

Convergence Insufficiency (CI) is the most common binocular vision anomaly among school-going children since they engage in prolonged near work. On the other hand, accommodation is the crystalline lens of the eye to adjust its dioptric power when viewing near work. Convergence and accommodation are always yoked together. Hence any adjustment that is done on the former still affects the latter. The most effective treatment for CI is vision therapy. The study aimed to determine the effects of vision therapies on accommodation among school-going children attending with CI attending the Masinde Muliro University Academic Vision Center in Kenya. The study used a comparative experimental study design where 46 participants with a mean age of 14 ± 2 years were recruited to participate. There were 16(35.4%) males and 30(64.6%) females distributed into two groups of home-based vision therapy carried at home and office-based vision therapy performed in the office for nine weeks. Shapiro Wilks test was performed to ascertain whether or not the data was normally distributed. The Paired t-test and Wilcoxon test were used to compare mean values within the groups, and the independent t-test was used to compare mean values between groups. The mean value of negative relative accommodation (NRA) before and after home-based therapy was statistically significant ($p=0.01$). However, the mean values before and after home-based therapy for the near point of accommodation (NPA), dynamic (Lag), relativity (PRA), and facility (MAF) showed no difference ($p>0.05$). The mean value of the NRA before and after office-based vision therapy was statistically significant ($p=0.01$). However, the mean values before and after office-based therapy for the near point of accommodation (NPA), dynamic (Lag), relativity (PRA), and facility (MAF) were statistically insignificant ($p>0.05$). The comparison between office-based vision therapy and home-based vision therapy showed no significant difference in accommodation. The study also noted that office-based and home-based vision therapy had the same effect on accommodation. These results imply that when the patient has CI and accommodation problems, the treatment should combine both vergence and accommodation therapy to bring the desired therapy except on NRA, which will respond to CI vision therapy alone.

TABLE OF CONTENTS

DECLARATION	ii
COPYRIGHT	iii
DEDICATION	iv
ACKNOWLEDGEMENT	v
ABSTRACT	vi
TABLE OF CONTENTS	vii
LIST OF TABLES	x
LIST OF FIGURES	xi
LIST OF ABBREVIATION AND ACRONYMS	xii
OPERATIONALIZATION OF TERMS	xiii
CHAPTER ONE: INTRODUCTION	1
1.0 Introduction.....	1
1.1 Background Information for the study.....	1
1.2 Problem Statement of the Study	3
1.3 Objectives of the Study	4
1.3.1 Broad objective	4
1.3.2 Specific Objectives	5
1.4 Research Hypothesis.....	5
1.5 Justification of the Study	6
1.6 Significance of the Study	6
1.7 Scope of the Study	6
1.7.1 Limitations.....	6
CHAPTER TWO: LITERATURE REVIEW	8
2.0 Introduction.....	8
2.1 Definition, distribution, and treatment modalities of convergence insufficiency	8
2.2 Accommodation of the Eye	12
2.2.1 Components of Accommodation	12
2.2.2 Influence of Vision Therapy on Accommodation Types.....	17
2.2.3 Treatment Modalities of Accommodations Anomalies	17
2.3 Home Based Vision Therapies	18
2.4 Office-Based Vision Therapy	19
2.5 Interrelation of accommodation and convergence	20

CHAPTER THREE: MATERIALS AND METHODS	22
3.0 Introduction.....	22
3.1 Study Area	22
3.2 Study Design.....	22
3.3 Study Population.....	23
3.3.1 Inclusion Criteria	23
3.3.2 Exclusion Criteria	23
3.4 Description of Methods	24
3.4.1 Sample Size Determination.....	24
3.4.2 Selection of Patients and Sampling Technique.....	25
3.5 Treatment of participants	25
3.5.1 Home-Based Pencil Push-Up Vision Therapy.....	25
3.5.2 Equipment used included.....	26
3.6 Office-Based Vision Therapy	27
3.6.1 Office-based VT/Orthoptics Vision Therapy.....	27
3.7 Treatment and Follow-up.....	29
Allocation	30
Analysis	30
Follow-Up.....	30
3.8 Data Analysis	31
3.8.1 Data Management and Storage	32
3.9 Logistics and Ethical Considerations.....	33
CHAPTER FOUR: RESULTS	35
4.1 Introduction.....	35
4.2 Baseline data of accommodation in participants with convergence insufficiency before treatment	35
4.3 The effects of home-based convergence insufficiency vision therapy on accommodation	37
4.4 The effects of office-based convergence insufficiency vision therapy on types of accommodation.....	39
4.5 The difference between uses of office-based and home-based CI vision therapies on accommodation among patients visiting Masinde Muliro university academic vision center, Kakamega	41

CHAPTER FIVE: DISCUSSION.....	43
5.1 Introduction.....	43
5.2 Demographic distribution and accommodation types at baseline before initiation of the therapy	43
5.3. Effect of home-based vision therapy on types of accommodation during treatment of CI	44
5.4 Effects of office-based convergence insufficiency vision therapy on accommodation ...	45
5.5 A comparison of mean differences between home-based vision therapy and office-based vision therapy on different types of accommodation after treatment	47
CHAPTER SIX: 48CONCLUSIONS AND RECOMMENDATIONS	48
6.1 Introduction.....	48
6.2 Conclusions.....	48
6.3 Recommendations.....	49
REFERENCES.....	50
APPENDICES	58
APPENDIX I: INFORMED CONSENT (PARENTS/ LEGAL GUARDIANS).....	58
APPENDIX II: ASSENT FORM.....	59
APPENDIX III: SUBJECT INSTRUCTIONS - PENCIL PUSH-UP (PENCIL PUSH-UP GROUP)	60
APPENDIX IV: INFORMATION DOCUMENT (PARENT/S)	61
APPENDIX V: INFORMATION DOCUMENT (CHILDREN)	63
APPENDIX VI: APPROVAL LETTER FROM POSTGRADUATE STUDIES	64
APPENDIX VII: APPROVAL LETTER FROM INSTITUTIONAL ETHICS REVIEW COMMITTEE	65
APPENDIX VIII: APPROVAL FROM NACOSTI	66

LIST OF TABLES

Table 3.1 Treatment protocol in cycle one 27

Table 3.2 The treatment protocol in cycle two 28

Table 3.3 Expected accommodative testing values based on Morgan’s expected
criterion..... 29

Table 3.4 Summarized structure for table analysis and presentation..... 32

Table 4.1 Comparison of baseline data for the treatment groups home-based and
office-based vision therapies. 36

Table 4.2. Comparison of the treatment for the home-based before and after therapy
..... 37

Table 4.3: Comparison of the means of office-based vision therapy before and after
therapy 39

Table 4.4: A comparison of mean differences between home-based vision therapy
and office-based vision therapy on accommodation after treatment..... 41

LIST OF FIGURES

Figure 2.1 Feedback mechanism.....	20
Figure 3.1 Randomization treatment and follow-up	30
Figure 3.2 Flow chart showing the data collection parameters	31
Figure 4.1: Gender distribution of the study participants.	36

LIST OF ABBREVIATION AND ACRONYMS

AA:	Amplitude of accommodation
AF:	Accommodative facility
BAF	Binocular accommodative facility
CI:	Convergence insufficiency
CISS:	Convergence insufficiency symptom survey
CITT:	Convergence insufficiency treatment trial
CPM:	Cycles per minute
D:	Diopter
HBVT:	Home-based vision therapy
MAF:	Monocular Accommodative Facility
NPA:	Near point of Accommodation
NRA:	Negative Relative Accommodation
OBVT:	Office-based vision therapy
PRA:	Positive Relative Accommodation

OPERATIONALIZATION OF TERMS

Accommodation – The eye's ability to adjust the crystalline lens's dioptric power during focusing between far and near distances.

Convergence – The movement of two eyes in the opposite direction to fuse the image two images as one.

Relative accommodation- The measure of accommodation when the target is fixed at 40 cm to depicts low and high.

The amplitude of accommodation - The near point through which the individual accommodation is at the threshold.

Vision therapy- The process of treating the eye using exercises.

CHAPTER ONE

INTRODUCTION

1.0 Introduction

This chapter provides the background information to this study and details the knowledge gap that forms the basis of this investigation. The section also describes the rationale for the study, aims and objectives, significance, and overall structure of the dissertation.

1.1 Background Information for the study

Vergence involves eye movements in the opposing directions to bring about fusion due to binocular fixation, while accommodation is the ability to change focus from one point to another as the crystalline lens changes the dioptric power (Kim *et al.*, 2014).

Convergence insufficiency (CI) is the most common binocular vision anomaly which is characterized by blurred vision, headache, short comprehension span, difficulty in concentration, eyestrain, frequent diplopia, and tired eyes after near work activities (Scheiman *et al.*, 2011; Singh *et al.*, 2017; Sreenivasan & Bobier, 2015). The most common and practical treatment for CI is vision therapy (Scheiman, 2009; Sweeney *et al.*, 2014). This vision therapy is divided into home and office-based therapy and uses base-out prisms to improve the demand by overstretching the reserve (Aletaha *et al.*, 2018).

Accommodation is defined as the crystalline lens adjustment, which changes the dioptric power that allows near objects to be focused onto the retina. The ability to accommodate reduces with an increase in age in humans and mammals (Werner *et al.*, 2000). The gradual and continuous loss of human accommodative amplitude begins early in life, which results in a complete loss of accommodation by the age of

50 to 55 years (Croft *et al.*, 2001). Studies have shown that the change in the eye's ability to focus (amplitude of accommodation) to age declines linearly thus can easily be predicted. In this regard, the correction of distance refractive error among the patient's age can be determined within one and a half years by measuring the near point of accommodation (Werner *et al.*, 2000).

Accommodation and vergence are parallel systems that have opposing cross-links (Esteve-Taboada *et al.*, 2017). Tonic vergence, which is part of vergence, occurs due to normal extraocular muscle tone with no accommodation and no stimulus of binocular vision always supports this vergence and accommodation together (Sreenivasan & Bobier, 2014). The adjustment of tonic vergence is responsible for reducing fixation disparity, which results in fusion due to ocular alignment (Sreenivasan & Bobier, 2014). Vergence adaptation adjusts the vergence system to bring about the desired outcomes through vision therapy such as orthoptic or prisms.

During the management of accommodative dysfunction, the response of accommodative adaptation acts to reduce the error that eventually normalizes the cross-link between vergence and accommodation (Scheiman, 2016). This outcome is referred to as accommodative convergence (Singh *et al.*, 2017). As a result of tonic adjustment between the vergence and accommodation along the primary cross-link, attenuation results in actual change in gain or loss of accommodation convergence accommodation ratio (AC/A) and convergence accommodation convergence ratio (CA/C) that vary with individual and direction of gaze (Sweeney *et al.*, 2014).

Management of vergence disorder requires an accurate approach so that minimal error should be experienced to reduce accommodative and vergence conflict, which causes visual discomfort to patients (Kim *et al.*,2014). Studies show that accommodation, however, despite being controlled by the autonomic nervous system, can also respond to a voluntary command (Scheiman, 2009). A study by Scheiman *et al.*, 2011 showed reduced with the low accommodative facility during treatment of various accommodative dysfunction; no information was provided on how its manipulation can eventually improve non-quantified values.

(2009) showed how vision therapy influences accommodation response (mostly near point of accommodation and facility). The study revealed a conflict during treatment from normal during the start of the therapy to a slight reduction after six weeks of 20 minutes of therapy each day.

1.2 Problem Statement of the Study

Convergence insufficiency (CI) occurs due to the vergence system's failure to hold binocular vision due to intense near work activities. Thus, the vision must keep up with constantly shifting directional stimuli (Ukai & Howarth, 2008). Failure to adjust during such changes is CI, which exists as a conflict between vergence and accommodation, which results in visual discomfort. The most affected population is school going children of ages 9 to 18 since they spend much of their time reading and other related activities. Most researchers (Momeni-Moghaddam, 2018; Scheiman, 2016; Sweeney *et al.*, 2014) attribute that if there exist vergence and accommodation anomalies, treat accommodation first before treating vergence. None of the studies has shown the effects of treatment of vergence to accommodation.

The most applicable treatment of choice is vision therapy (Scheiman *et al.*, 2011; Cotter *et al.*, 2008; Sreenivasan & Bobier, 2015). Vision therapy is divided into two categories based on treatment and includes; Home-based vision therapy, which is undertaken at home using a pencil or broke strings, and office-based therapy, which entails using computer software with other handhelds near target stimuli.

The most used therapy with desired results is office-based vision therapy (Scheiman, 2016). The studies have shown little efficacy, which sets the stage for further investigation of why the treatment of choice does not give a high success rate. Their failure is attributed to close monitoring and commitment by the patient. This study focused on CI's treatment with office-based vision therapy and home-based vision therapy while monitoring accommodation that entailed the response, relativity, and facility for nine weeks.

1.3 Objectives of the Study

1.3.1 Broad objective

To determine the effects of convergence insufficiency vision therapies on accommodation among school-going children attending the Masinde Muliro University Academic Vision Centre in Kenya.

1.3.2 Specific Objectives

1. To establish the baseline accommodation status among school-going children with CI attending the Masinde Muliro University Academic Vision Center prior to CI vision therapy.
2. To determine the effect of home-based CI vision therapy on accommodation among school-going children attending the Masinde Muliro University Academic Vision Center.
3. To determine the effects of office-based CI vision therapy on accommodation among school-going children attending Masinde Muliro University Academic Vision Center.
4. To compare the effects of home-based and office-based CI vision therapies on accommodation among school-going children attending the Masinde Muliro University Academic Vision Center.

1.4 Research Hypothesis

- Ho1: Effects of home-based and office-based convergence insufficiency (CI) vision therapies on accommodation not significant
- Ho2: Effects of office-based and home-based CI vision therapies on accommodation not significantly different
- Ha1: Home- and office-based convergence insufficiency vision therapies significantly affect accommodation
- Ho2: Effects of office-based and home-based CI vision therapies on accommodation are significantly different

1.5 Justification of the Study

- No evidence of study on effect of CI vision therapy on accommodation in Kenya
- Continued increase in prevalence of CI
- Contribute to knowledge of baseline data for vergence and accommodation.
- Comprehensive management of CI.

1.6 Significance of the Study

The results of this study provided baseline data on the proper treatment of CI and accommodative by clinicians. This investigation provided the actual data on how the accommodative components are affected when manipulating vergence. These results confirm the hypothesis of treating the accommodation first before treating the vergence. The study also did not find the difference in home-based and office-based vision therapies in treating binocular vision anomalies.

1.7 Scope of the Study

The study focused on those patients who had been diagnosed with convergence insufficiency and undergoing vision therapies using home-based therapy and office-based therapy while monitoring accommodative components. The study was limited to measuring near point of accommodation, accommodation facility, lag and lead of accommodation, negative relative accommodation, and positive relative accommodation.

1.7.1 Limitations

- Duration of the therapy was short.
- Lack of control group and masking of both examiners and participants.

- Small sample size might have also affected the outcome

CHAPTER TWO

LITERATURE REVIEW

2.0 Introduction

This chapter provides a review of the literature concerning the interaction between vergence and accommodation. Various treatment methods of convergence insufficiency.

2.1 Definition, distribution, and treatment modalities of convergence insufficiency

Among the vergence anomalies, CI has the highest prevalence and characterized by blurred vision, headache, short comprehension span, difficulty in concentration, eyestrain, frequent diplopia, tired eyes feeling sleepy after close work activities (Scheiman *et al.*, 2011; Singh *et al.*, 2017; Sreenivasan & Bobier, 2015). The most commonly used treatment based on clinical research evidence is vision therapy (Scheiman, 2014).

The prevalence of CI varies across the globe and has been reported to range from 1.75%-33%, with an average of approximately 5% (Cooper & Jamal, 2012; Norn, 1966; Shippman *et al.*, 1983). In the United States, the prevalence was reported to range from 2.5%-8.35% among children and adults (Cooper and Duckman, 1978; Lara *et al.*, 2001; Rouse *et al.*, 1999; Shippman *et al.*, 1983; Stidwill, 1997).

A British survey found out that nearly one in every 300 children suffered from CI (Stidwill, 1997) and a study conducted in Spain found that in symptomatic patients in an optometric clinic, one in every 100 (0.8%) had CI (Lara *et al.*, 2001).

A study in Romania revealed that three in every five (60.8%) adolescents who complained of blurred vision during near work suffered from CI (Dragomir *et al.*, 2001). The prevalence of CI in an Iranian population was reported by (Hashemi *et al.*, 2017) to be 5.6% and 16.5% in rural and 17.6% in urban areas of India (Hussaindeen *et al.*, 2017).

A study aimed at determining the status of binocular dysfunction among children in South Korea found CI to be the most prevalent (Jang & Park, 2015). The prevalence estimates from low, high, definite, and pseudo-CI were 11.8%, 6%, 4.3%, and 1.9%, respectively, in a population of high school students in South Africa (Wajuihian & Hansraj, 2016). A study on the prevalence of CI among students in Khartoum, Sudan, Africa revealed a majority of CI of 7.8% (Hassan *et al.*, 2018).

Convergence insufficiency is more prevalent in middle age individuals and those in high school or college due to high demand for near work (Triantafilou *et al.*, 2014). A study to estimate CI's prevalence in Sudanese secondary schools revealed a significant difference in means between CI and type of school ($p < 0.05$). However, the study did not show any significant association between CI and sex ($p > 0.05$).

A typical Kenyan student's school day is between 7 am and 5:30 pm, and out of the 10 hours 30 minutes spent in school, 9 hours are used for studying. Furthermore, those in boarding school have night studies between 7 pm and 9 pm. The study period in school is the time intended for students to complete homework, catch up on missing assignments or study for tests and quiz, and therefore during this time, students perform a lot of near work.

The Kenyan curriculum for secondary school has twelve subjects in form one and two and has eight subjects in form three and four. Consequently, from the many

subjects students do, there is a possibility that they are overworked by the amount of information given. Every child and parent in the country knows that grades matter and teachers emphasize attaining good grades, especially in high school. Therefore long hours in class are just a part of preparing for the final examination, which determines admission into university (Abuya, 2017).

Vergence depicts the double contralateral movement of the eyes in the opposite direction, leading to the acquisition of single vision binocularly (Arnoldi & Reynolds, 2007). In vergence dysfunction, one's eyes cannot focus and stabilize the image on the retina accurately.

The definition of near work includes; reading and studying using the computer, watching and playing video games. From the former, for the close task to be accomplished, one would require functional convergence to align the two eyes on a visual target. Consequently, when the convergence is insufficient, one would experience asthenopic symptoms while under-taking near work—as a result, owing to the characteristic features of near remote sensing, a remote and decompensated esophoria near (Arnoldi & Reynolds, 2007).

These symptoms affect students' performance and quality of life (Sathyan *et al.*, 2017). Ackerman *et al.* (1999) noted that CI is not always present in children who experience blur and diplopia and concluded that this could be a normal physiological phenomenon. However, treating CI in those children with symptoms improved students' attention and internalizing (Borsting *et al.*, 2013).

To ascertain the nature of the occurrence and extent of such symptoms, those with CI are always reported as depicted on a convergence insufficiency symptom survey. The

severity of the symptoms reported by those with CI symptoms, using the convergence insufficiency symptom survey (Borsting *et al.*, 2003).

This tool was validated as a screening method for convergence insufficiency as reported by (Davis *et al.*, 2016). It is highly dependable when evaluating the symptoms and treatment efficacy in patients with CI of ages 9 to 18 years old with sensitivity and specificity of 96%.

The study by (Hashemi *et al.*, 2019) classified accommodative anomalies into four groups, whereby exclusion criteria also involved the presence of more than two clinical symptoms. They established normative values based on their studies. The amplitude of accommodation was determined using Hofstetter's formula, with a standard deviation of $\pm 2.00D$. According to age, monocular accommodative facilities were classified. The expected values were $5.5 \pm 2.5D$ for a six-year-old, $6.5 \pm 2.0D$ for a seven-year-old, and $7.0 \pm 2.5D$ for an eight to twelve-year-old. Adults were expected to have a value of $11 \pm 5.0D$. The same classification was used for binocular accommodative facilities whereby a six-year-old was expected to have a BAF of $3.0 \pm 2.5D$ and $3.5 \pm 2.5D$ for a seven-year-old child. Those within the age range of 8 to 12 years had a BAF of $5.0 \pm 2.5D$ while adults' expected value was $10 \pm 5.0D$. Monocular estimation methods and findings were estimated to be $0.50 \pm 0.50D$, PRA of $-2.37 \pm 0.50D$, and negative relative accommodation (NRA) of $+2.00 \pm 0.50D$ (Scheiman & Wick, 2013). The lack of consensus on the exact clinical diagnostic criteria informed this review.

2.2 Accommodation of the Eye

Accommodation plays a vital role in modifying the fixation disparity to enable the individual to fuse the image. Accommodation of the eye tends to reduce with increasing age in humans and mammals (Werner *et al.*, 2000). The gradual and continuous loss of human accommodative amplitude begins early in life and results in a complete loss of accommodation by age 50 to 55 (Croft *et al.*, 2001). Studies have shown that the change in the eye's ability to focus (amplitude of accommodation) to age declines linearly thus can easily be predicted.

2.2.1 Components of Accommodation

Accommodative components that lead to the quantification of measurable types include; tonic accommodation, which implies the physiological position of rest as the eye maintains continuous steady vergence (Scheiman, 2009). The proximal accommodation entails the near object and fusional accommodation, which works continuously to maintain a single image, thus avoiding diplopia (Scheiman, 2009). This component is always quantified using clinical tests such as facility, amplitude, relativity, and dynamism.

Accommodative Facility (AF) is defined as the eye's ability to change through a distance of focus while instantly maintaining the angle. It shows the eye's flexibility as it changes from near to distant and quantified with lenses that inhibit or stimulate accommodation (Mehta *et al.*, 2010). AF clinically depicts the functionality of ocular accommodative systems. Flipper of $\pm 2.00D$ or $\pm 1.50D$ lenses at a distance of 40 centimeters is used to test (Wick *et al.*, 2002). Based on a recent study (Wajuihian, 2018), the average values using the flippers aforementioned using binocular should range between 5 to 11 cycles per minute. Thus, in this study, these values were used to depict the average.

Accommodative insufficiency is an anomaly that has been characterized by the reduced amplitude of accommodation (Hashemi, Khabazkhoob, & Nabovati, 2019). Many clinicians use a single clinical sign criterion to diagnose accommodative insufficiency, while others disagree with this design and operate multiple clinical sign criteria (Ma *et al.*, 2019). Scheiman concluded that the best criteria are to employ an amplitude of accommodation of 2D less than mean of age using Hofstetter's formula and at least two signs of the four additional characters (Mitchell Scheiman & Wick, 2013). However, other researchers (29,30) disagreed with this design and concluded that only the amplitude of accommodation is essential in diagnosing accommodative insufficiency. Further studies by Russel and Wick used Duane's criteria and concluded that accommodative insufficiency is analyzed using the amplitude of accommodation 2.5D less than usual (Wahlberg *et al.*, 2010). Nonetheless, limited the design because the study did not indicate the reference point. Most results indicate different criteria with different literature values, and researchers disagree on the number of symptoms involved above the diminished amplitude of accommodation and their significance.

Due to this limitation, (Cacho *et al.*, 2002) studied the need for other symptoms apart from accommodation's reduced amplitude. The study concluded that patients with typical PRA values, NRA, and BAF would not have diminished accommodation amplitude, indicating that it is inappropriate to use the amplitude of accommodation as the only sign for diagnosing accommodative insufficiency.

Apart from classification criteria, there is a lack of consensus on the expected values for various clinical measures used to classify accommodative insufficiency. In 1950, Hofstetter compared data obtained from Duane and Donder and suggested three linear equations that improved accommodative insufficiency diagnosis. The limitation of his equations is that he based it on studies with loads regarding sample size, sample size selection, and data reliability. Morgan studied pre-presbyopia subjects and concluded that this group's normative findings are NRA of 2.0 ± 0.5 D and PRA of -2.3 ± 1.1 D (Morgan, 1944). These findings are limited in their application because there is a wide age range involved, yet studies have shown age as a variable affecting this normative value. Another survey by Wajuihian (2018) shows slightly different normative findings, where he concluded that the expected value for PRA is 2.1 ± 0.4 and NRA -2.4 ± 0.7 . In 1989, Scheiman studied the pediatric population and concluded that the average value for BAF is 5.2 ± 2.5 D (Scheiman *et al.*, 1989). Another study on a similar population indicated a normative BAF value of 14. (Hussaindeen *et al.*, 2015), (Abraham *et al.*, 2015) established the normative value for AA to be 9.9 ± 1.7 .

Accommodative excess is a condition in which the patient has difficulty relaxing accommodation and presents with asthenopia and headache (Ma *et al.*, 2019). Researchers apply a wide range of diagnostic criteria with a lack of uniformity on the cut-off points and the number of signs to be used to diagnose this condition.

The suggestion by (Lara *et al.*, 2001) that the best way to diagnose accommodative excess is the more significant number of signs. The results allowed him to develop a criterion that involved six clinical signs in which three were fundamental while the rest were complimentary. The vital signs were variable visual acuity, inconsistent retinoscopy findings, and MAF less than 6cpm. However, he limited his conclusion

because this was an assumption taken from other researchers, and there is inadequate evidence to support it.

(García-Muñoz et al., 2016) and (Shin et al., 2009) identified that high PRA $> 3.50D$ is related to accommodative excess. However, Garcia-Munoz's conclusion was biased as he did not do the analysis, making PRA not suitable as a fundamental sign. He substituted the results with MAF and set the limit to be 6cpm or less. The study also suggested that a patient must have visual symptoms in their history for accommodative excess diagnosed. Hussaindeen concluded that it could only diagnose accommodative excess if the patient has MEM < 0 and an esophoria at near more than $3\Delta D$ (Hussaindeen & Phil, 2017). In his criteria, he disputed the idea of variable visual acuity and inconsistent static retinoscopy findings used as fundamental signs. MEM's use as a vital sign by Wajuihian (2019) and his cut-off was MEM of 0.25D or less (Wajuihian, 2018). The study implies significant variation in criteria used and lack of evaluation of diagnostic accuracy of clinical signs.

Apart from diagnostic criteria, the norms established and their cut-off has a wide variation; thus, many studies illustrated where BAF and MAF are used to diagnose accommodative excess. Some researchers use BAF of 3cpm and MAF of 6cpm, while others use MAF of 4.5cpm and BAF of 2.5cpm. The suggestion needs a unified cut-off figure for norms that can refer to diagnosis accommodative excess.

Accommodative infacility occurs when the accommodative system is slow and making change leading to delayed accommodative responses. Scheinman and Wick (2004) concluded that there are two ways of diagnosing accommodative infacility. The first was a direct method based on difficulty clearing with the $\pm 2.00D$ lens when doing MAF leading to common findings of $< 4.5cpm$. Wick (2014) found

Indirect ways on patients failing with +/- 2.00D lens when doing BAF and common findings on < 2.5 cpm and PRA < -1.25 D and NRA $< +1.50$ D.

However, other studies(14,35) concluded that AA and MEM findings are expected in accommodative infacility, but PRA and NRA present abnormal results. Ming-Leung(2019) concluded that low MAF is the only vital sign to diagnose accommodative infacility with a cut-off of 6cpm (Ma et al., 2019) while other researchers (36,17,20) used multiple characters, thus indicating that there are varying norms in literature that used to diagnose accommodative infacility.

The Amplitude of Accommodation (AA) is defined as the eye's ability to increase the optical power of the crystalline lens of the eye to bring the object to clarity in reducing the retinal blur (Charman, 2008). It is determined clinically by using the RAF (royal air force) rule (push up method), and this has been reported to be a reliable measure by (Mathebula & Makunyane, 2017). Since the population under investigation include ages 9 to 18 years always has consistent results to normative of average 15- 0.25 of the period based on Hofstetter's minimal classification criteria, which are widely used as the baseline value for the amplitude of accommodation.

The accommodative response, which is also called relativity, is described as the extent to which the accommodation responds when stimulated or inhibited at a fixed distance of 40cm and measured using the values of (NRA) (PRA) are determined using plus lens and minus lens to blur point (Sreenivasan & Bobier, 2015).

The other accommodative is the dynamic response that will show the retinal blur, and this is usually measured using monocular estimation methods (Rouse *et al.*, 1999).

2.2.2 Influence of Vision Therapy on Accommodation Types

The autonomic nervous system always controls the state of accommodation. However, it can also respond to the voluntary command, as stated by Scheiman (2009). A study showed reduced with the low accommodative facility during treatment of various accommodative dysfunctions. The limited information provided on how its manipulation can eventually improve non-quantified values (Scheiman *et al.*, 2011).

Vasudevan *et al.* (2009) showed how vision therapy influences accommodation response (mostly amplitude and facility). The study revealed a conflict during treatment from normal during the start of the treatment to a slight reduction after six weeks of 20 minutes of therapy each day. Based on the above finding, the current study aimed to investigate how the accommodative components are affected and reduce or escalate the symptoms and their influence on overall therapy.

2.2.3 Treatment Modalities of Accommodations Anomalies

Some of the person's accommodative components to be symptomatic include amplitude, response, and facility. Accommodation anomalies treated with low-powered plus lenses result in normalizing the focusing accuracy, thus reducing fatigue when performing near vision tasks (Sweeney, Seidel, Day, Gray, *et al.*, 2014). If necessary, vision therapy can be carried out to develop more normal abilities to sustain focus for extended periods, to adjust by focusing from near to far and back; and to ensure focusing and convergence abilities are working together (Cacho-Martínez *et al.*, 2010). Scheiman *et al.* (2011) noted that vision therapy improves accommodation and facility amplitude in school-going children presented with symptomatic CI and accommodative dysfunction.

2.3 Home Based Vision Therapies

Home-based vision therapy, as the name suggests, is a procedure that is carried at home by the patients themselves and has fewer office visits (Scheiman, 2016). The patient is given proper instruction on carrying out the procedure at home, followed by reinforcement through daily phone calls to the caregivers. In most cases, the patients with CI who underwent vision therapy using pencil push up showed marked improvements in symptoms after six weeks (Vasudevan *et al.*, 2009). Momeni-Moghaddam *et al.* (2015) carried out a study on 60 students and younger adults than 19 years with manifest CI. The researcher used home-based vision therapy with pencil push up compared with office-based vision therapy. The study results showed that both home-based and office-based treatments were statistically significantly comparable in terms of efficacy. The study combined both accommodative and vergence manipulations; Moghaddam *et al.* (2015) hence quantified the measure of vergence while components although he did not monitor accommodation despite their treatment.

Scheiman (2016) carried out a comparative study between home-based computer vergence with home-based near target push up therapy having a placebo as a control. This case-controlled study was carried out on 204 children aged between 9 and 18 years. The study had challenges in terms of follow up and sample management such that the outcome was difficult to ascertain the treatment. This study contradicted the expected results, which always showed success to the treatment, thus giving false positives in placebo treatment. The difference in the percentage of participants with a successful outcome in the HB-C group compared with the HB-PU group was 4% ($p = 0.56$), and the HB-P group was 5% ($p = 0.52$). The study had all components of the treatment modalities; however, the purpose was not achieved.

Nehad *et al.* (2018) compared the therapeutic yield of a patient with manifest CI undergoing office-based therapy to those undergoing home-based therapy patients with symptomatic CI. The study was conducted on 102 patients aged 13 years. The treatment's success rate was 47%, which was equivalent to 48 out of 102 patients. The study only focused on the changes that are done on vergence and little done on accommodation. Sweeney *et al.* (2014) used a total of 14 participants to investigate the interaction of vergence and accommodation and how they are yoked together for the fine retinal image to be viewed.

This study further showed the importance of monitoring the accommodation components when doing orthoptics. In a randomized clinical trial, Rouse *et al.* (2009) involved 221 students ages 9 to 17 years who presented with symptomatic CI and compared home-based pencil push-up to office-based computer vergence and accommodative that took 12 weeks duration. The study was based on a convergence insufficiency survey sheet to monitor the success rate, which could not quantify the values of accommodation well with vergence values.

2.4 Office-Based Vision Therapy

Office-based vision therapy is the type of orthoptic training carried in the office with a series of procedures aimed at stabilizing binocular dysfunction (Chen, 2013). Nehad *et al.* (2018) investigated vision therapy effectiveness using a sample size of 78 patients. Those who reported having a successful CI treatment outcome were 36.5%, while 32.7% showed slight improvement.

Scheiman *et al.* (2005) investigated how office-based vision therapy influences accommodation and vergence. The primary measure used as baseline data before the therapy initiation was; accommodative amplitude, facility, age, and race. In the group that was undergoing the pencil push-ups on average, the facility was 6.7 cycles per

minute while the amplitude was 15.6 D. For office-based vision therapy, the facility 8.4 cycles per minute, and the amplitude of accommodation was 12.5 D. After the treatment, the study only revealed the influence of the treatment on vergence and how the symptoms reduced. However, the study did not report any significant difference before and after the therapy on accommodation.

2.5 Interrelation of accommodation and convergence

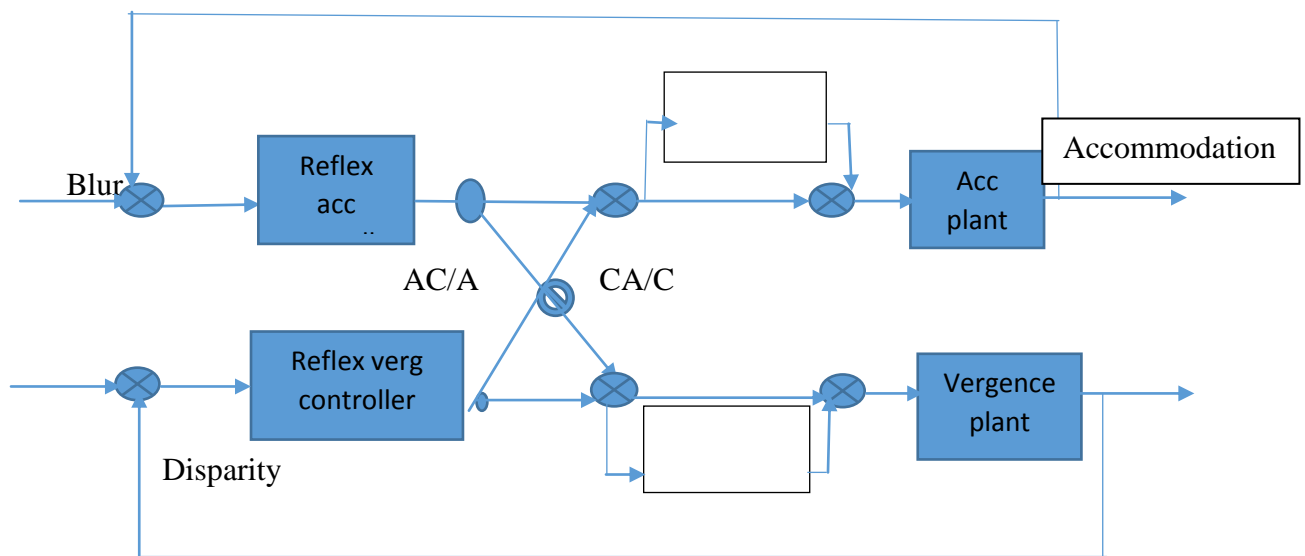

Figure 2.1 Feedback mechanism

Figure 2.1 is a model adapted from the convergence insufficiency treatment trial group (CITT), which explains the yoking nature of vergence (Scheiman *et al.*, 2011).

During the diagnosis of convergence insufficiency, the patient's parameter includes symptoms and signs experienced by the patient that manifest by clinical examination (Triantafilou *et al.*, 2014). There exists different clinical criterion for diagnosing convergence insufficiency (Borsting *et al.*, 2003; Borsting *et al.*, 1999; Dwyer, 1991; Marran *et al.*, 2006; Rouse *et al.*, 2009), and different researchers have given contrasting definitions on how to diagnose convergence insufficiency (Cooper & Jamal, 2012).

The most common signs of CI are remote NPC and poor fusional convergence amplitudes. Other clinical symptoms associated with CI include exodeviation from near, reduced AC/A ratio, and a low vergence facility (Mazow *et al.*, 1989; Noorden *et al.*, 2002; van-Leeuwen *et al.*, 1999; Wright, 2003).

For normal young adults, maintaining convergence near is relatively easy, and they can easily keep it up to 1-2cm from the bridge of the nose, whereas it can be slightly tricky for adults who usually can keep it up to 3-4cm range (Cacho-Martínez *et al.*, 2013). Many authors have used a remote NPC of 10cm to define patients with CI (Lepore, 1995; Mazow *et al.*, 1989; van Leeuwen *et al.*, 1999; Wright, 2003).

The investigation by Sheard's suggests that reserves must be two times the amount of phoria for the patient to be comfortable (Daum, 1988). The average values of convergence amplitudes for distance and near are 38 prism diopters and 14 prism diopters at a distance, respectively (Harley *et al.*, 2005). Those having amplitudes of less than 15-20 prism diopters at near are considered to have CI (Mitchell *et al.*, 2008; Wright, 2003). Thus vision therapy is recommended to alleviate such anomaly, and patients with CI have also been shown to have heterophoria (Daum, 1988; Rosenbaum & Santiago, 1999; M. Scheiman *et al.*, 2005). Several authors agree that high exophoria should be used to diagnose CI with positive fusional convergence and receded NPC (Cacho-Martínez *et al.*, 2014).

CHAPTER THREE

MATERIALS AND METHODS

3.0 Introduction

This chapter details the research design used, study population, sample and sampling procedures used, data gathering instruments, the process for data collection, data analysis, and ethical considerations.

3.1 Study Area

This study took place at Masinde Muliro University of Science and Technology/Academic Vision Center (MMUST/AVC) in Kakamega County, Kenya. The choice of MMUST AVC as the setting for the study was because there is a Department of Optometry and Vision Sciences, Pediatric Optometry Unit, the only clinical, research, and academic Optometry Unit in Western Kenya. The unit provides research opportunities in child eye health, particularly in binocular vision. For this study, the section was a convenient facility for assessing and managing accommodation and convergence insufficiency.

3.2 Study Design

The researcher used a comparative experimental study design. Those children diagnosed with convergence insufficiency were distributed into two treatment groups of home-based pencil-push up therapy and office-based computer vision therapy using random computer sampling.

3.3 Study Population

The researcher carried out the study on school-going children of ages nine years to 18 years. The investigation was possible because, according to previous studies, the prevalence of convergence insufficiency is more pronounced from ages 9 to 19 (Scheiman *et al.*, 2011). Therefore the study used the same population age group. The school-going children attending the MMUST/AVC during June 2019 were recruited to participate in the study. The group was actively engaged in near work tasks since they were at school, and prolonged near work was among the precursor of CI (Sweeney *et al.*, 2014). Since the number of patients visiting the clinic was approximately 50 per month, the number was used to estimate the sample size in this study.

3.3.1 Inclusion Criteria

The researcher recruited patients seeking treatment or coming for routine eye care attending the Academic Vision Center (AVC) to participate in the study. The selection criteria included; those children between 9 and 19 years of age, exophoria at near 4PD greater than distance. Those with reduced positive fusion vergence at near that was defined as less than 20PD, failure to meet Sheard's criteria, receded NPC (breakpoint of 6cm and higher using a near target), meet the convergence insufficiency symptom survey, had the best-corrected vision of 6/6 at a distance and 20/20 at near (Aletaha *et al.*, 2018; Scheiman 2008).

3.3.2 Exclusion Criteria

The researcher excluded children with the disease known to affect vergence and accommodation, those with a previous history of strabismus surgery, the difference in NPC above 20cm in either eye. Those with primary vertical heterophoria greater than 1PD and distance or near exophoria greater than 10PD.

3.4 Description of Methods

3.4.1 Sample Size Determination

The minimum sample size (n) for this study was derived using the formula (Charan & Biswas, 2013).

$$n = \frac{[Z_{(\alpha)} \sqrt{2P(1-P)} + Z_{(\beta)} \sqrt{P_1(1-P_1) + P_2(1-P_2)}]^2}{(P_1 - P_2)^2}$$

Where, n = minimum sample size used for this comparative study

$P_1 = 80\%$, taken from the finding of Scheiman *et al.* (2005) study representing the proportion of CI patients undergoing offices based therapy.

$P_2 = 27.3\%$ = representing the proportion of CI patients undergoing the treatment of home-based pencil push up therapy used in the Ohio State University study= 0.273

$$P = \frac{P_1 + P_2}{2}$$
$$= \frac{0.80 + 0.273}{2}$$

$$P = 0.5365$$

$$Z_{(\alpha)0.05} = \text{Standard normal deviation at } 5\% = 1.960.$$

$$Z_{(\beta)0.05} = \text{Standard normal deviation at } 5\% = 1.645.$$

Therefore, given the above, the minimum sample size for this study was thus;

$$n = \frac{[1.960 \sqrt{2 \times 0.5365(1-0.5365)} + 1.645 \sqrt{0.80(1-0.80) + 0.273(1-0.273)}]^2}{(0.80 - 0.273)^2}$$

$$n = \frac{[1.960 \times 0.7052 + 1.645 \times 0.5987]^2}{0.2777}$$

$$n = \frac{[1.3821 + 0.9849]^2}{0.2777}$$

$$n = \frac{5.6027}{0.2777}$$

$$0.2777$$

$$n = 20.175 \cong 21.$$

Allowance for Attrition = 10 % of 21= 2.1

Hence, minimum size, for the study = 21 + 2.1 = 22.1 \cong 23 subjects in each group.

In this regard, the total sample to be recruited was 46

3.4.2 Selection of Patients and Sampling Technique

The total population of those patients at MMUST/AVC that fell in the study bracket in a month and were diagnosed with CI were, on average, 50 children. The researcher retrieved records for children who had visited June 2019. They had been diagnosed with CI without being subjected to any treatment. The principal investigator contacted them and explained the nature and the procedures of the study. Those who met the minimum criteria outlined above received the information document to read before signing the consent.

The researcher distributed the 46 selected children were randomized into two groups using computer-generated random sampling. The groups were the home-based pencil-push up vision therapy group and the office-based vision therapy group, with 23 participants.

3.5 Treatment of participants

3.5.1 Home-Based Pencil Push-Up Vision Therapy

Participants in this study received explicit instructions to carry out the treatment. The written instructions entailed the procedure to do pencil push-up. Before initiating the therapy, the investigator conducted practice sessions with the participants and guided them through the instructions. The researcher discussed other details were during the weekly therapy appointment sessions and subsequent phone calls. The weekly visits

and communication entailed emphasis on compliance and correction of any problems that arose.

The study took nine weeks to complete and was in two phases. During this period, the groups visited the clinic once a week to measure accommodative components and monitor the therapy's progress. The forms used to collect data were issued to the patients at the beginning of the research and explained the procedures. These forms were from the convergence insufficiency trial treatment group (CITT) and adapted to a similar group before being used in this study. The documents included CITT Pencil Push-up therapy subject instructions. Appendix III

3.5.2 Equipment used included

Alphabet pencil, White index card, Centimeter ruler

3.5.3 Procedure of the Therapy

The procedure

The child stood in front of the wall while holding a card. The content's orientation was vertical, measuring 6 to 8 feet from the wall at eye level. The subject then held the pencil at arm's length directly between his/her eyes and the card from the wall. The child reported seeing one clear letter on one pencil and two cards in the background when looking at them. He/she moved the pencil slowly towards his/her nose while maintaining the eyes on the letter on the card and keeping in mind the two cards from the wall with the peripheral vision. The researcher requested the child to report when the cards moved far apart as the pencil came closer. In case one card disappeared, the child had to blink and see both cards.

The subject was requested to keep looking at the card while maintaining it as single as possible as he/she moved it closer to the nose steadily. When the subject could no

longer keep it clear, he/she was asked to continue trying to make it single to stop moving the pencil and try to get the letter back to one. At this point, it is okay if the letter is one but blurry.

Before the subject was allowed to carry out the therapy at home, the researcher made sure the child had demonstrated the ability; to complete at least 5 minutes of push-ups, to measure the distance at which the subject experienced the break after 5 minutes, and to enter the results on the data collection form.

3.6 Office-Based Vision Therapy

The therapy entailed the participants going through a series of therapy for nine weeks in two phases, which began with the simplest to more complex tasks. Each participant had 60 minutes of in-office treatment sessions.

3.6.1 Office-based VT/Orthoptics Vision Therapy.

Table 3.1 Treatment protocol in phase one

Protocol Phase one		
Test	Duration	Endpoint
Brock string	Week one to week four	Converge to bead 2.5cm distance from the nose
Barrel card		Make sure that three barrels within three seconds fuse then hold fusion for 5 seconds, for ten repetitions
VTS4 level 1		15 Δ base-in with large RDS targets 25 Δ base-out, 12 Δ base in (letter L) 45 Δ base out with large RDS targets
Eccentric		15 Δ base in and 30 Δ base out

Table 3.1 showing the outline followed during the first phase of vision therapy in office-based vision therapy.

Table 3.2 Treatment protocol in phase two

Phase two treatment protocol		
Test	Duration	Results
VTS4 level 2	Four weeks	Fuse alternately 25 Δ base out and 15 PD base in for ten cycles in 1minute
Eccentric circle jump		Switch in between chiasopic and fusion with cards held at 6cm apart 20 times
Lifesaver cards		the patient should be in a position to clear all the four5 seconds

Table 3.2 showing the treatment followed during phase two of office-based vision therapy

The above protocol was done within nine weeks, of which one week was used to assess the progress before the continuation of the therapy. The successful treatment measure was monitored by evaluating the NPC, fusional vergence, and convergence insufficiency symptom survey (CISS) found in the appendix.

The following were measured and recorded: near point of accommodation (NPA), a relativity that includes positive relative accommodation (PRA) and negative relative accommodation (NRA), facility test, and dynamic retinoscopy for lead and lag. The unit measure of these tests was diopters.

Table 3.3 Expected accommodative testing values based on Morgan's expected criterion

Type of accommodation	Methods used	Expected findings	Standard Deviation
Near point of accommodation	Push up test	15- 1/4 age	± 2.00 D
Accommodative facility	RAF rule ± 2.00 D	8- 12 years 7cpm 13 to 30 years 11cpm	± 2 cpm
Accommodative response (relativity)	NRA PRA	+2.00 D - 2.37 D	± 0.50 D ±1.00 D
Dynamic response	MEM	+0.50 D	± 0.25D

Source: (Theodore, 2007)

Table 3.3 showing the values of accommodation expected during the measurement of individual components.

3.7 Treatment and Follow-up

Figure 3.1- CONSORT flow diagram of the process of allocation, treatment follow-up, and analysis for the randomized clinical treatment of vision therapy for CI patients. The study assessed participants to participate in the investigation, where 59 were eligible. After subjection to inclusion criteria set in methodology, only 46 met while 13 did not meet. Randomization was done, as shown in the figure above and follow up. However, only 21 in the group of OBVT were analyzed as the two participants were lost during the follow-up. In the group of HBVT, five people were lost during follow-up as indicated in the consort above; thus, only 18 participants were analyzed.

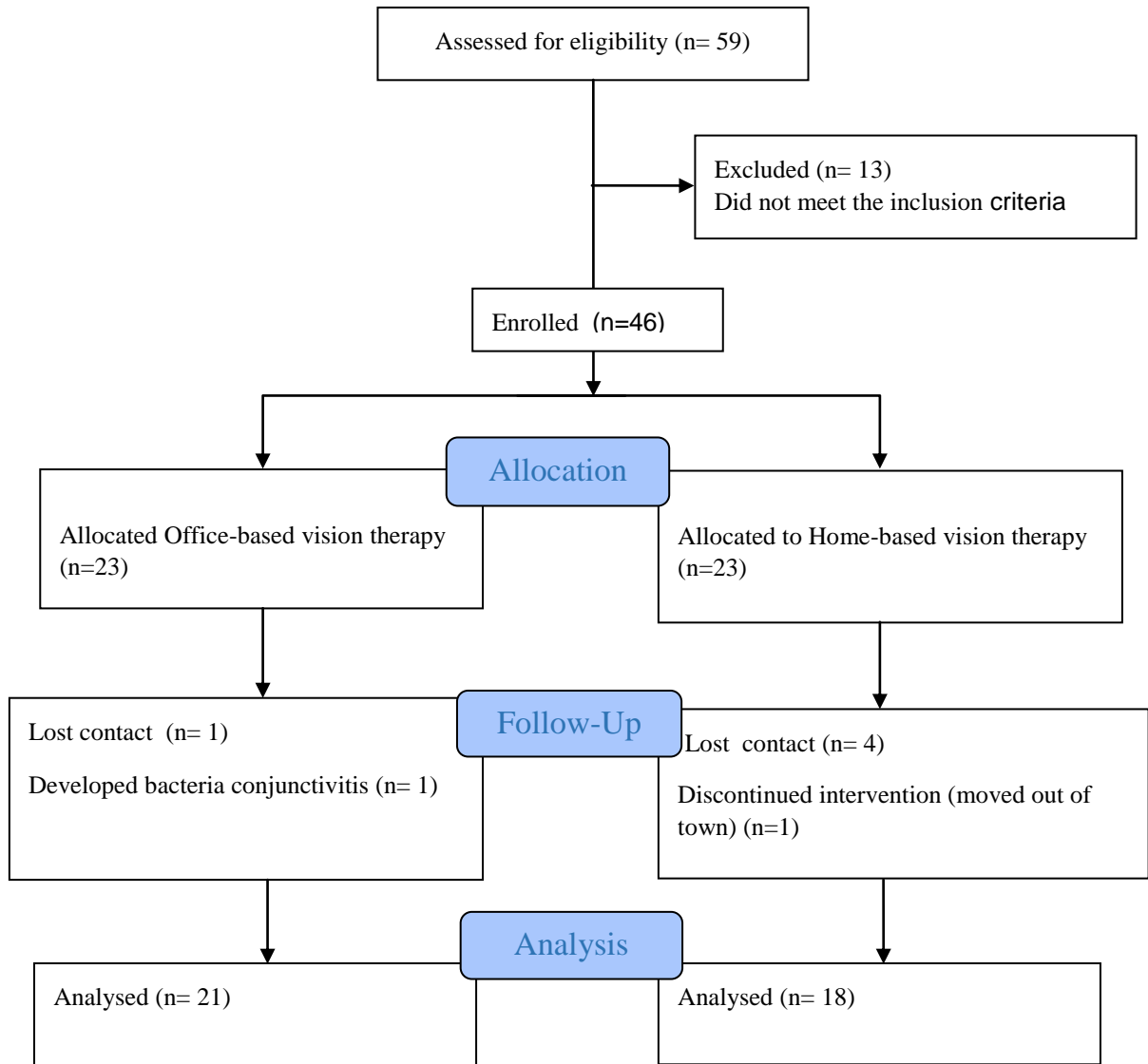

Figure 3.1 Treatment and follow-up

Data Collection Flow Chart

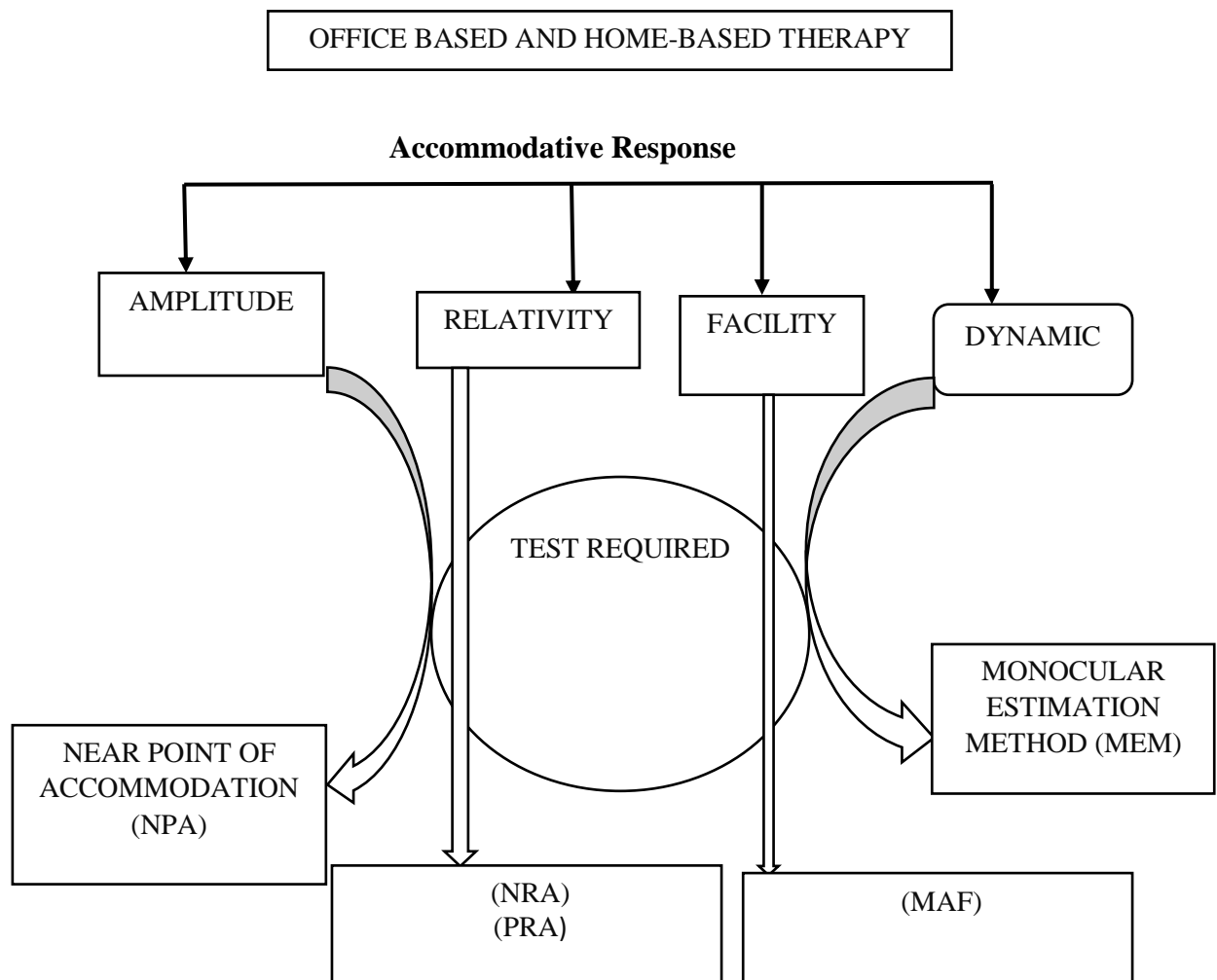

Figure 3.2 Flow chart showing the data collection parameters

3.8 Data Analysis

The Shapiro Wilk test was used to detect departure from normality. Descriptive statistics were used to analyze the distribution of the type of accommodation and vergence adjustments during the treatment of CI, interaction of vergence, and accommodation before and after treatment CI.

3.8.1 Data Management and Storage

The measurement was entered in the Excel spreadsheet, cleaned and exported into Statistical Package for Social Sciences (SPSS version 25) for analysis using various tools.

Table 3.4 Summarized structure for table analysis and presentation

s/n	Study objectives	Dependent variables (variable type)	Independent variables (variable type)	Statistical tools for analysis	Data presentation plan
1.	To determine the baseline data of all accommodative types before commencing the treatment.	Amplitude (continuous) Facility (continuous) Relativity(continuous) Response(continuous)		Frequencies ; Mean and standard deviation (SD)	Table
2.	Effects of office-based vision therapy on accommodation during CI treatment	Amplitude(continuous) Facility(continuous) Relativity(continuous) Response(continuous)	Office-based vision therapy	Paired t-test Wilcoxon	Tables
3.	Effect of home-based vision therapy on accommodation during CI treatment	Amplitude(continuous) Facility(continuous) Relativity(continuous) Response(continuous)	Home-based therapy	Paired t-test Wilcoxon	Tables
4.	To determine the significant difference between the use of office-based and home-based CI vision therapies on accommodation	Amplitude(continuous) Facility(continuous) Relativity(continuous) Response(continuous)	Office base and home-based therapy	Independent t-test	Tables

3.9 Logistics and Ethical Considerations

Permission to conduct this study was obtained from Masinde Muliro University Academic Vision Center (AVC), where the tests were conducted. Ethical clearance was obtained from the Institution Ethical Research Committee (IERC) Clearance – MMUST, Kakamega, and the National Commission for Science Technology and Innovation (NACOSTI).

Participant Consent- Since the research was dealing with minors, participants' parents and caregivers were informed of the study's purpose and the fact that participation is voluntary and that participation can be terminated at any time the subject deems necessary. Upon confirmation that the intended participant has understood the terms of their participation in the study, he/ she was requested to give verbal consent, which was noted. Consent was also obtained from all participants. All the information about the procedures to be undertaken was explained, benefits, risks, and any relevant concerns were addressed before consent /assent was obtained.

Confidentiality of information and the identity of participants was maintained. All data collection sheets were labeled by serial number and not identifiable characteristics. The researchers did not reveal the identity of anyone undergoing vision therapy.

Tokens for participation in the study were provided since the research involved minors who traveled once per week to come for the therapy or because data collection took a considerable amount of time. Snacks and refreshments were also provided to all the participants.

Autonomy of the participant was respected as those who requested to get out of study were allowed. Before they left they were informed other available treatment to continue at their convenience as indicated in appendix I

CHAPTER FOUR

RESULTS

4.1 Introduction

The chapter describes vision therapy's effects on accommodation using home-based vision therapy and office-based vision therapy. The researcher presented the results according to the objectives of the study.

4.2 Baseline data of accommodation in participants with convergence insufficiency before treatment

The baseline data were recorded before the commencement of the therapy. The variables were computed for measures of central tendency for forty-eight participants who were recruited into the study. Their age ranged from 10 to 17 years, with a mean of 14 ± 2 . There were 14 (35.9%) males and 25 (64.1%) females resulting in a male to female ratio of approximately 1:2. The mean values of the monocular accommodative facility (MAF) for the right and left eyes was 9.65 ± 2 cycles per minute and 9.50 ± 2 cycles per minute, respectively. For binocular accommodative facility, the mean value was 6.43 ± 2 cycles per minute. The mean positive relative accommodation (PRA) for the right eye, 2.1 ± 0.92 D, and 1.97 ± 0.72 D for the left eye. The mean negative relative accommodation (NRA) for the right eye was 2.10 ± 0.85 D and 2.10 ± 0.85 D for the left eye. The mean near point of accommodation (NPA) for the right eye was 8.87 ± 1.97 D and 8.87 ± 1.99 D for the left eye. The mean value dynamic accommodation (lag) in the right eye was 0.43 ± 0.34 D and 0.44 ± 0.36 D in the left eye.

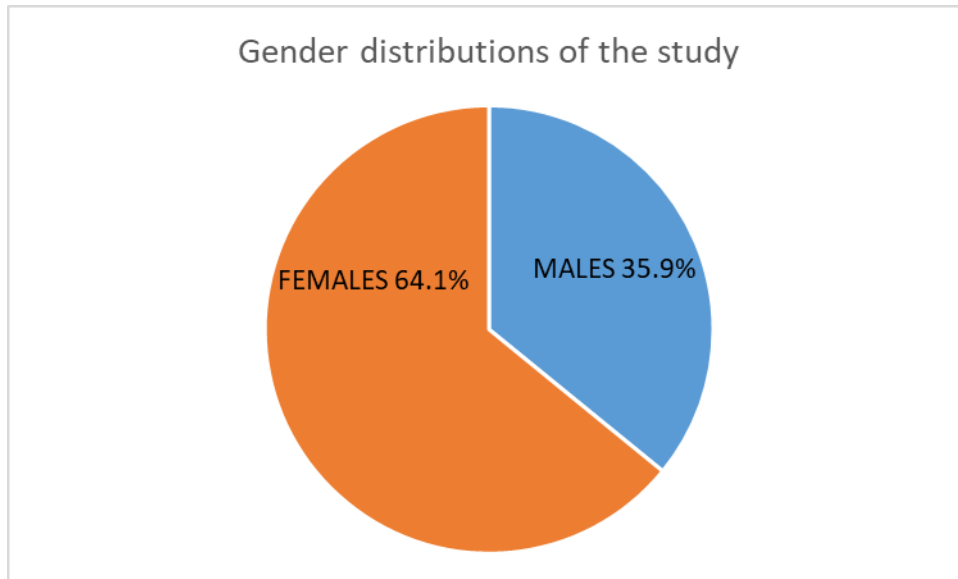

Figure 4.1: Gender distribution of the study participants.

Table 4.1 Comparison of baseline data for the treatment groups home-based and office-based vision therapies.

ACCOMMODATION	HBVT BASELINE N= 18	OBVT BASELINE N=21	P-VALUE
MAFRE (CPM)	9.67(2.65)	9.14(2.83)	0.48
MAFLE (CPM)	9.61(2.61)	9.00(2.73)	0.55
PRARE (D)	2.36(0.86)	2.02(0.81)	0.22
PRALE (D)	2.36(0.86)	2.02(0.81)	0.22
NRARE (D)	2.15(1.03)	1.89(0.82)	0.38
NRALE (D)	2.09(0.91)	1.84(0.78)	0.36
NPARE (D)	9.27(2.15)	8.64(2.08)	0.35
NPALE (D)	9.22(2.21)	8.57(2.11)	0.41
LagRE (D)	0.50(0.29)	0.38(0.29)	0.21
LagLE (D)	0.54(0.28)	0.38(0.32)	0.10

CPM= cycles per minute, D= diopters.

HBVT, home-based vision therapy, OBVT, office-based vision therapy, MAFRE, monocular accommodation facility for the right eye, MAFLE, a monocular accommodative facility for the left eye, PRARE, positive relative accommodation for the right eye, PRALE, positive relative accommodation for the left eye, NRA, negative relative accommodation for the right eye, NPARE, near the point of accommodation for the right eye, NPALE near the point of accommodation for the left eye. The data presented as means and standard deviation. $P < 0.05$ was considered significant.

4.3 The effects of home-based convergence insufficiency vision therapy on accommodation

The study sought to find out the effects of home-based convergence insufficiency vision therapy on types of accommodation.

Table 4.2. Comparison of the treatment for the home-based before and after therapy

BEFORE TREATMENT N=18	AFTER 9 WEEKS TREATMENT N=18			
ACCOMMODATION	MEAN (SD)	MEAN (SD)	P-VALUE	Effect size
MAFRE (CPM)	9.67 (2.65)	10.22 (1.66)	0.17	0.34
MAFLE (CPM)	9.61 (2.61)	10.11 (1.67)	0.24	0.30
PRARE (D)	2.36 (0.86)	2.50 (0.56)	0.36	0.25
PRALE (D)	2.36 (0.86)	2.50 (0.56)	0.45	0.25
NRARE (D)	2.15 (1.03)	2.52 (0.66)	0.02	0.56
NRALE (D)	2.09 (0.91)	2.47 (0.54)	0.01	0.70
NPARE (D)	9.27 (2.15)	9.36 (1.05)	0.83	0.08
NPALE (D)	9.22 (2.21)	9.38 (1.03)	0.68	0.15
LagRE (D)	0.50 (0.29)	0.54 (0.28)	0.58	0.14
LagLE (D)	0.54 (0.28)	0.47 (0.18)	0.50	0.38

CPM= cycles per minute, D= diopters.

MAFRE, monocular accommodation facility for the right eye, MAFLE, a monocular accommodative facility for the left eye, PRARE, positive relative accommodation for the right eye, PRALE, positive relative accommodation for the left eye, NRA, negative relative accommodation for the right eye, NPARE, near the point of accommodation for the right eye, NPALE near point of accommodation for the left eye. The data presented as means and standard deviation $p < 0.05$ bolded.

The mean near point of accommodation for the right eye before the therapy was 9.27 ± 2.16 D and 9.36 ± 1.06 D after completion of treatment. Similarly, the mean near point of the left eye's accommodation before treatment was 9.22 ± 2.21 D and 9.38 ± 1.03 D after treatment. However, the mean difference before and after treatment was statistically insignificant ($p = 0.83$ and $p = 0.68$ for the right and left eyes, respectively).

The mean MAF of the right eye before treatment was 9.67 ± 2.65 CPM and 10.22 ± 1.66 CPM after treatment. The mean difference before and after treatment was statistically insignificant ($p= 0.17$). The mean MAF for the left eye before treatment was 9.61 ± 2.61 CPM and 10.11 ± 1.67 CPM after treatment. As with the right eye, the difference between mean MAF before and after therapy for the left eye was statistically insignificant ($p=0.24$).

Wilcoxon signed-rank test analysis was used for negative relative accommodation as the data was not normally distributed. The mean negative relative accommodation at the beginning of therapy was 2.15 ± 1.03 D and 2.52 ± 0.66 D after therapy. The mean difference before and after therapy was statistically significant ($p= 0.02$).

A paired t-test was used to compare the mean NRA and PRA values before and after home-based vision therapy. NRA's mean for the left eye was 2.09 ± 0.91 D and 2.47 ± 0.54 D after therapy. The mean difference before and after therapy was statistically significant ($p= 0.01$). The mean positive relative accommodation of the right eye before therapy was 2.36 ± 0.86 D and 2.50 ± 0.56 D after therapy. The mean difference before and after therapy was statistically insignificant ($p=0.36$). The mean of the left eye at baseline was 2.36 ± 0.86 D and 2.50 ± 0.56 D after therapy. Similarly, the mean difference before and after therapy was statistically insignificant ($p=0.45$).

The mean dynamic accommodative response (lag) of the right eye before therapy was 0.50 ± 0.29 D and 0.54 ± 0.28 D after therapy. The mean difference before and after therapy was statistically insignificant ($p=0.58$). The mean dynamic accommodative response of the left eye before therapy was 0.47 ± 0.18 D and 0.47 ± 0.18 D after therapy. Similarly, the mean difference before and after therapy was statistically insignificant ($p=0.26$).

4.4 The effects of office-based convergence insufficiency vision therapy on types of accommodation

Most of the accommodative variables of office-based vision therapy were not normally distributed; hence non-parametric statistics were used for analysis.

Table 4.3: Comparison of the means of office-based vision therapy before and after therapy

ACCOMMODATION	BEFORE TREATMENT N=21		AFTER 9 WEEKS TREATMENT N=21		Effect size	
	(SD)	MEAN	(SD)	MEAN		P-VALUE
MAFRE (CPM)		9.14 (2.83)		9.19 (1.66)	0.89	0.03
MAFLE (CPM)		9.00 (2.73)		9.09 (1.57)	0.78	0.05
PRARE (D)		2.02 (0.81)		2.19 (0.34)	0.20	0.50
PRALE (D)		2.02 (0.81)		2.21 (0.32)	0.11	0.59
NRARE (D)		1.89 (0.82)		2.17 (0.78)	0.08	0.37
NRALE (D)		1.84 (0.78)		2.13 (0.49)	0.01	0.59
NPARE (D)		8.64 (2.08)		8.71 (1.61)	0.66	0.04
NPALE (D)		8.57 (2.11)		8.71 (1.61)	0.50	0.08
LagRE (D)		0.38 (0.29)		0.35 (0.32)	0.60	0.09
LagLE (D)		0.38 (0.32)		0.36 (0.16)	0.79	0.12

CPM= cycles per minute, D= diopters.

MAFRE, monocular accommodation facility for the right eye, MAFLE, a monocular accommodative facility for the left eye, PRARE, positive relative accommodation for the right eye, PRALE, positive relative accommodation for the left eye, NRA, negative relative accommodation for the right eye, NPARE, near point of accommodation for the right eye, NPALE near point of accommodation for the left eye. The data presented as means and standard deviation p<0.05 bolded.

The mean near point of accommodation for the right eye before therapy was 8.64 ±2.08 D and 8.71 ± 1.61 D after therapy. The mean difference before and after therapy was, however, statistically insignificant (p=0.66). The means near point of accommodation of the left eye before therapy was 8.57 ± 2.11 D and 8.71 ± 1.61 D after therapy. The mean difference before and after therapy was statistically insignificant (p=0.50). The mean monocular accommodative facility of the right eye

before therapy was 9.14 ± 2.83 cycles per minute and 9.19 ± 1.66 cycles per minute after therapy. The mean difference before and after therapy was statistically insignificant ($p=0.89$). Similarly, the mean MAF of the left eye before therapy was 9.00 ± 2.73 cycles per minute and 9.09 ± 1.54 cycles per minute after therapy. The difference in means before and after therapy was statistically insignificant ($p=0.78$).

The mean NRA value for the right eye before therapy was 1.89 ± 0.82 D and 2.13 ± 0.53 D after therapy. The difference between mean NRA before and after therapy was statistically insignificant ($p=0.80$). Contrary to the left eye, the mean NRA before therapy was 1.84 ± 0.78 D and 2.13 ± 0.49 D after therapy, with the mean difference before and after treatment was statistically significant ($p=0.01$).

The mean positive relative accommodation before therapy was 2.02 ± 0.81 D and 2.19 ± 0.34 D after therapy. A paired t-test was used to compare the mean difference before and after therapy and was statistically insignificant ($p=0.20$). Before therapy, the mean PRA of the left eye was 2.02 ± 0.81 D and 2.21 ± 0.32 D after the therapy. Wilcoxon sign rank was used to compare the mean before and after therapy, and the difference was statistically insignificant ($p=0.11$).

The mean dynamic accommodative response (lag) for the right eye before therapy was 0.38 ± 0.29 D and 0.35 ± 0.16 D after therapy. The mean difference before and after therapy was statistically insignificant ($p=0.60$). The mean dynamic accommodative response (lag) for the left eyes before therapy was 0.38 ± 0.32 D and 0.36 ± 0.16 D after therapy. Similarly, the mean dynamic accommodative response (lag) difference before and after therapy was statistically insignificant ($p=0.79$).

4.5 The difference between uses of office-based and home-based CI vision therapies on accommodation among patients visiting Masinde Muliro university academic vision center, Kakamega

Leven's test for equality of variance was conducted, and an independent sample t-test showed that there was no significant difference in the use of two therapies (home-based therapy and office-based therapy) in 9 weeks of training with regards to accommodation measurement (amplitude, relativity, facility, and response)

Table 4.4: A comparison of mean differences between home-based vision therapy and office-based vision therapy on accommodation after treatment

ACCOMMODATION	HBVT 9 weeks of therapy N= 18	OBVT weeks of therapy N=21	p-VALUE	Effect size
MAFRE (CPM)	10.22(1.66)	9.19(1.66)	0.06	0.62
MAFLE (CPM)	10.11(1.66)	9.09(1.54)	0.06	0.66
PRARE (D)	2.50(0.56)	2.19(0.34)	0.06	0.47
PRALE (D)	2.50(0.56)	2.21(0.32)	0.07	0.90
NRARE (D)	2.52(0.66)	2.13(0.49)	0.07	0.79
NRALE (D)	2.47(0.54)	2.17(0.53)	0.10	0.56
NPARE (D)	9.36(1.05)	8.71(1.61)	0.15	0.40
NPALE (D)	9.38(1.03)	8.71(1.61)	0.13	0.41
LagRE (D)	0.47(0.18)	0.35(0.16)	0.06	0.75
LagLE (D)	0.47(0.18)	0.35(0.16)	0.08	0.75

CPM= cycles per minute, D= diopters.

HBVT, home-based vision therapy, OBVT, office-based vision therapy, MAFRE, monocular accommodation facility for the right eye, MAFLE, a monocular accommodative facility for the left eye, PRARE, positive relative accommodation for the right eye, PRALE, positive relative accommodation for the left eye, NRA, negative relative accommodation for the right eye, NPARE, near point of accommodation for the right eye, NPALE near point of accommodation for the left eye. The data presented as means and standard deviation. $P < 0.05$ was considered significant.

The participants who completed the therapy were 18 in home-based vision therapy and 21 in office-based vision therapy. Comparing the end of the therapy treatment between office-based-vision therapy and home-based vision therapy was insignificant.

CHAPTER FIVE

DISCUSSION

5.1 Introduction

This chapter gives the interpretation and explanation of the findings presented in chapter four. It also shows how the findings of the present study relate to those of other studies.

5.2 Demographic distribution and accommodation types at baseline before initiation of the therapy

The study subjected the selected participants to a normality test and showed that the distribution showed homogeneous characteristics hence no bias as shown in (Table 4.1). The gender distribution in the current study is consistent with that found by Scheiman *et al.* (2008), which also had more females compared to males as illustrated in figure 4.1. This was attributed by many scholars arguing the increase in girls' child empowerment and increased enrollment in school in Kenya. It may also be linked to free education systems that have given girls going to school compared to females. The near point of accommodation was low for the right and left eyes compared to the expected near point of accommodation as per the mean age of the study using Hofstetter's minimum (Abraham *et al.*, 2015). In comparison with the near point of accommodation was on the lower limit. This is so because the dysfunction of vergence directly affects accommodation due to the structural correlation.

The monocular accommodative facility of right and left eyes, when compared to the expected values (Maxwell *et al.*, 2012), was lower, but similar to those obtained in studies by Cacho-Martínez *et al.* (2014) and Rouse *et al.* (1999). This implies that a reduction in vergence functionality leads to reduced MAF. The baseline data of

positive relative accommodation for the right and left eyes compared to the expected mean value as per Theodore (2007) showed that the participants had normal values as the standard deviations were within the expected limits. The negative relative accommodation of the study's right and left eyes were comparable to the study reported by Wajuihian (2018) in a South African black population. However, the study by Wajuihian was looking at the normative data in which the participants had no other conditions as opposed to the study in which the participants had CI. In this regard, more studies should be done on the normative data of vergence. The mean dynamic accommodative response showed that the lag of accommodation values found in the current study was consistent with the normal values reported by Allen *et al.* (2010). As a result, for the participants who had CI, the lag of accommodation was not affected.

5.3. Effect of home-based vision therapy on types of accommodation during treatment of CI

The comparison of the participant's treatment before and after nine weeks is shown in table 4.2. The mean difference of the near point of accommodation before and after the therapy had a positive deviation towards normalcy and comparable to the study by Scheiman (2016). Since the mean value was within the normal values, Wajuihian (2018) stated there was no statistical significance. Studies by Manley (2013) and Scheiman (2016) focused on improving both vergence and accommodation during treatment of convergence, but the values of near point of accommodation were not documented. The mean monocular accommodative facility of the right eye and left eye before and after treatment was low. Another study that had a similar outcome despite using accommodative flippers on training had a mean change of 1.90 (Allen *et al.*, 2010). The results of negative relative accommodation for the right and left

eye showed varied outcomes. The mean difference for the right eye was statistical and clinical significance. Similarly, the left eye's mean value depicted the same effect, having a clinical and statistical effect. In this study, the use of home-based vision therapy for the treatment of convergence insufficiency without combining accommodative therapy is still affected. Other studies (Jang *et al.*, 2017; Manley, 2013) that conducted similar therapy used a combined method and found that accommodative exercises played a minute role. The study's findings also indicated that the use of home-based vision therapy had no significant effect on positive relative accommodation of the right eye and left eye. These results could have been influenced by the fact that they were within limits compared to normal values (Wajuihian, 2018). The study also established that most subjects with convergence insufficiency had normal positive relative accommodation. Other studies on positive relative accommodation showed no change before and after training, respectively (Vasudevan *et al.*, 2009). The similarities in these studies show that in cases where the subjects have low positive relative accommodation, home-based vision therapy may not be the treatment of choice. The mean dynamic accommodative response before and after therapy was statistically insignificant, suggesting that subjects with convergence insufficiency did not have problems with a lag of accommodation, comparable with the study by Langaas *et al.* (2008).

5.4 Effects of office-based convergence insufficiency vision therapy on accommodation

The negative relative accommodation findings of right and left eyes didn't show any clinical and statistical effect before and after therapy, with the mean being within limits of the normal values after therapy. This compares well with the normal values established by Wajuihian and Hansraj (2016). The study by Jang *et al.* (2017),

however, indicated that during therapy, there was an improvement of negative relative accommodation with high recovery of symptomatic convergence insufficiency patients. The results might be attributed to the long duration of twelve weeks of therapy, while the current study only took nine weeks. This shows that patients with convergence insufficiency having reduced negative relative accommodation when undergoing office-based vision therapy; both accommodative and vergence exercises should be employed. Before and after therapy, the positive relative accommodation did not show any statistically significant difference in the right and left eyes. The mean values of positive relative accommodation were consistent with Abraham et al.'s normative values. The therapy also compared the mean before and after office-based vision therapy for the monocular accommodation facility, and the results showed no significant difference. The study by Kulp *et al.* (2009) attributed the improvement of accommodative facility compared to the normal expected values to have manipulated the accommodative system; however, it did not quantify the magnitude using similar 12 weeks duration therapy. The mean dynamic accommodative response (lag) before and after the right and left eye therapy were statistically insignificant. The values of the lag of accommodation before and after the study were within the mean value for the normative by Allen *et al.* (2010). This shows that patients with convergence insufficiency are likely to have a normal lag of accommodation.

5.5 A comparison of mean differences between home-based vision therapy and office-based vision therapy on different types of accommodation after treatment

The comparison between the use of office-based-vision and home-based vision therapy on the treatment of convergence insufficiency patients significantly affected symptom score. The results are consistent with the study by Abubakar *et al.* (2012). However, the main aim was to monitor the accommodation as the treatment was being given. There was no difference between the means after therapies using office-based and home-based vision therapies on accommodation and home-based and office-based for the PRA, NPA, MAF, and lag of accommodation. However, there was a significant difference between the mean negative relative accommodation when using office-based and home-based vision therapies.

There was no statistically significant difference between office-based and home-based vision therapies for the accommodative values before and after the therapy. This means that the use of office-based vision therapy in treating convergence insufficiency is not superior to home-based vision therapy on accommodation, and both therapies have the same effects. However, studies by Manley (2013), Scheiman *et al.* (2005), and Sweeney *et al.* (2014) suggested that the use office-based vision therapy was superior as compared to home-based vision therapy. These studies only looked at the use of vision therapy to manage convergence insufficiency, but the accommodative values were not documented. The study by Scheiman *et al.* (2002) found out that most clinicians use home-based vision therapy with other reinforcement to bring the desired therapeutic effect. The study further emphasized that there is no difference in either therapy in treating convergence insufficiency patients, as reported by both optometrists and ophthalmologists as reported by Scheiman *et al.* (2002).

CHAPTER SIX

CONCLUSIONS AND RECOMMENDATIONS

6.1 Introduction

This chapter summarizes the study findings and suggests some recommendations and a way forward for possible future studies in this area.

6.2 Conclusions

According to the study results, the accommodative types measured before treatment were on the lower limit of the normal values compared to Hofstetter's minimum values for the patients with convergence insufficiency. The baseline values were important since they were monitored for any improvement or reduction as the therapies were being administered. This shows that patients who have convergence insufficiency will depict.

Home-based vision therapy for the patients with CI had significant effects on accommodation, changing from a lower limit to average after the therapy. The therapy had the same effect when used with accommodative therapy on accommodation, despite showing no statistically significant difference. However, the difference was clinically significant since the values were normal at the end of the therapy.

The use of office-based vision therapy still had clinical effects despite being statistically insignificant. The use of combined therapy for both vergence and accommodative exercises still had the same effect, although not quantified.

There was no significant difference between using home-based and office-based therapies, as both had the same effects on accommodation.

6.3 Recommendations

The findings from this study showed that the therapies had effects of accommodation. They also had significant effects on the NRA. The comparison between the use of home-based and office-based also had no significant difference. Based on this finding, the following comments were made;

When using vision therapy, office-based vision therapy (OBVT), and home-based vision therapy (HBVT), in the treatment of CI, if the patient has PRA, NPA, MAF, and lag of accommodation anomalies, the therapy should incorporate the use of accommodative exercise to enhance the response or the period of the therapy should be elongated to reach a threshold of the therapy.

When the patient has CI with NRA anomalies, the use of vision therapy will treat both without accommodative exercise.

The use of HBVT and OBVT have no significant difference since they had similar results; thus, any of the vision therapy may be used in the treatment of CI.

Gender did not influence the therapy as both male and female had a similar outcome; thus, no special consideration should be taken when treating the participants

REFERENCES

- Abraham, N., Srinivasan, K., & Thomas, J. (2015). Normative data for near point of convergence, accommodation, and phoria. *Oman Journal of Ophthalmology*, 8(1), 14–18.
- Abu Bakar, N. F., Ai Hong, C., & Pik Pin, G. (2012). COVD-QOL questionnaire: An adaptation for school vision screening using Rasch analysis. *Journal of Optometry*, 5(4), 182–187.
- Abuya, B. (2017). Why the new education curriculum is a triumph for Kenya's children. *The Conversation*. Retrieved from <https://theconversation.com/why-the-new-education-curriculum-is-a-triumph-for-kenyas-children-75090>
- Aletaha, M., Daneshvar, F., Mosallaei, M., Bagheri, A., & Khalili, M. R. (2018). Comparison of three vision therapy approaches for convergence insufficiency. *Journal of Ophthalmic and Vision Research*, 113(3),307-314.
- Allen, P. M., Charman, W. N., & Radhakrishnan, H. (2010). Changes in the dynamics of accommodation after accommodative facility training in myopes and emmetropes. *Vision Research*, 50(10), 947–955.
- Allen, P. M., Hussain, A., Usherwood, C., & Wilkins, A. J. (2010). Pattern-related visual stress, chromaticity, and accommodation. *Investigative Ophthalmology and Visual Science* 51(12), 6843-6849.
- Arnoldi, K., & Reynolds, J. D. (2007). A Review of Convergence Insufficiency: What are we Accomplishing with Exercises? *American Orthoptic Journal*, 57(1), 123–130.
- Borsting, E. J., Rouse, M. W., Mitchell, G. L., Scheiman, M., Cotter, S. A., Cooper, J (2003). Validity and reliability of the revised convergence insufficiency symptom survey in children aged 9 to 18 years *Optometry & Vision Science*, 80(12), 832–838.
- Borsting, E, Rouse, M. W., & De Land, P. N. (1999). Prospective comparison of convergence insufficiency and normal binocular children on CIRS symptom surveys. Convergence Insufficiency and Reading Study (CIRS) group. *Optometry and Vision Science* : 76(4), 221–228.

- Borsting, Eric, Mitchell, G. L., Arnold, L. E., Scheiman, M., Chase, C., Kulp, M., ... Group, C. (2013). *Behavioral and Emotional Problems Associated With Convergence Insufficiency in Children : An Open Trial* 20(10), 836-844.
- Cacho-Martínez, P., García-Muñoz, Á., & Ruiz-Cantero, M. T. (2010). Do we know the prevalence of accommodative and nonstrabismic binocular dysfunctions? *Journal of Optometry* 3(4), 185-197
- Cacho-Martínez, P., García-Muñoz, Á., & Ruiz-Cantero, M. T. (2013). Diagnostic validity of clinical signs associated with a large exophoria at near. *Journal of Ophthalmology* 3(2010), 185-197.
- Cacho-Martínez, P., García-Muñoz, Á., & Ruiz-Cantero, M. T. (2014). Is there any evidence for the validity of diagnostic criteria used for accommodative and non strabismic binocular dysfunctions? *Journal of Optometry*, 7(1), 2–21.
- Charan, J., & Biswas, T. (2013). How to calculate sample size for different study designs in medical research? *Indian Journal of Psychological Medicine* 35(2), 121–126.
- Charman, W. N. (2008). The eye in focus: Accommodation and presbyopia. *Clinical and Experimental Optometry* 91(3), 207-225.
- Chen, D. L. (2013). Treatment of convergence insufficiency: a review. *American Orthoptic Journal*, 19(August), 72–77.
- Cooper, J., & Duckman, R. (1978). Convergence insufficiency: incidence, diagnosis, and treatment. *Journal of the American Optometric Association*, 49(6), 673–680.
- Cooper, J., & Jamal, N. (2012). Convergence insufficiency: A major review. *Optometry (St. Louis, Mo.)* 83(4):137-158.
- Croft, M. A., Glasser, A., & Kaufman, P. L. (2001). Accommodation and Presbyopia. *International Ophthalmology Clinics*, 41(2), 33–46.
- Daum, K. M. (1988). Characteristics of convergence insufficiency. *American Journal of Optometry and Physiological Optics*, 65(6), 426–438.

- Davis, A. L., Harvey, E. M., Twelker, J. D., Miller, J. M., Leonard-Green, T., & Campus, I. (2016). Convergence Insufficiency, Accommodative Insufficiency, Visual Symptoms, and Astigmatism in Tohono O'odham Students. *Journal of Ophthalmology* 1(2010), 23- 27.
- Dragomir, M., Truş, L., Chirilă, D., & Stîngu, C. (2001). Orthoptic treatment efficiency in convergence insufficiency treatment. *Oftalmologia (Bucharest, Romania : 1990)*, 53(3), 66–69.
- Dwyer S, P. Ba. Los. (, 1991). Clinical criteria for vergence accommodation dysfunction. *Clinical and Experimental Optometry*, 74(4), 112–119.
- Esteve-Taboada, J. J., Del Águila-Carrasco, A. J., Bernal-Molina, P., López-Gil, N., Montés-Micó, R., Kruger, P., & Marín-Franch, I. (2017). Dynamic accommodation without feedback does not respond to isolated blur cues. *Vision Research*, 136, 50–56.
- Harley, R. D., Nelson, L. B., & Olitsky, S. E. (2005). *Harley's pediatric ophthalmology*. (5th ed.). Philadelphia, Pa.: Lippincott Williams & Wilkins.
- Hashemi, H., Nabovati, P., Khabazkhoob, M., Ostadimoghaddam, H., Doostdar, A., Shiralivand, E., & Yekta, A. (2017). The prevalence of convergence insufficiency in Iran: a population-based study. *Clinical and Experimental Optometry*, 100(6), 704–709.
- Hassan, L. I., Ibrahim, S. M., Abdu, M., & MohamedSharif, A. (2018). Prevalence of convergence insufficiency among secondary school students in Khartoum, Sudan. *Oman Journal of Ophthalmology*, 11(2), 129–133.
- Hussaindeen, J. R., Rakshit, A., Singh, N. K., George, R., Swaminathan, M., Kapur, S., ... Ramani, K. K. (2017). Prevalence of non-strabismic anomalies of binocular vision in Tamil Nadu: report 2 of BAND study. *Clinical and Experimental Optometry*, 100(6), 642–648.
- Jang, J., Tai-Hyung, K., & Moon, H. (2017). Effectiveness of vision therapy in schoolchildren with symptomatic convergence insufficiency. *Journal of Ophthalmic and Vision Research*, 12(2), 187–192.

- Jang, J. U., & Park, I.-J. (2015). Prevalence of general binocular dysfunctions among rural schoolchildren in South Korea. *Taiwan Journal of Ophthalmology*, 5(4), 177–181.
- Kim, J., Kane, D., & Banks, M. S. (2014). The rate of change of vergence-accommodation conflict affects visual discomfort. *Vision Research*, 105, 159–165.
- Kim, K. M., & Chun, B. Y. (2011). Effectiveness of Home-Based Pencil Push-ups (HBPP) for Patients with Symptomatic Convergence Insufficiency. *Korean Journal of Ophthalmology*, 25(3), 185.
- Kulp, M., Mitchell, G. L., Borsting, E., Scheiman, M., Cotter, S., Rouse, M., ... Reuter, K. (2009). Effectiveness of placebo therapy for maintaining masking in a clinical trial of vergence/accommodative therapy. *Investigative Ophthalmology and Visual Science*, 50(6), 2560–2566.
- Langaas, T., Riddell, P. M., Svarverud, E., Ystenaes, A. E., Langeeggen, I., & Bruenech, J. R. (2008). Variability of the accommodation response in early-onset myopia. *Optometry and Vision Science*, 85(1), 37–48.
- Lara, F., Cacho, P., García, A., & Megías, R. (2001). General binocular disorders: prevalence in a clinic population. *Ophthalmic and Physiological Optics*, 21(1), 70–74.
- Lepore, F. E. (1995). Disorders of Ocular Motility Following Head Trauma. *Archives of Neurology*, 52(9), 924–926.
- Manley, G. (2013). *Public Access NIH Public Access*. 71(2), 233–236.
- Marran, L., De Land, P. N., & Nguyen, A. L. (2006). Accommodative Insufficiency Is the Primary Source of Symptoms in Children Diagnosed With Convergence Insufficiency. *Optometry and Vision Science*, 83(5), 281–289.
- Mathebula, S. D., & Makunyane, P. S. (2017). The amplitude of accommodation is reduced in pre-presbyopic diabetic patients. *Journal of Endocrinology, Metabolism, and Diabetes of South Africa*, 22(1), 64–68.

- Maxwell, J., Tong, J., & Schor, C. M. (2012). Short-term adaptation of accommodation, accommodative vergence, and disparity vergence facility. *Vision Research*, *62*, 93–101.
- Mazow, M. L., France, T. D., Finkleman, S., Frank, J., & Jenkins, P. (1989). Acute accommodative and convergence insufficiency. *Transactions of the American Ophthalmological Society*, *87*(72), 158–168.
- Mitchell Scheiman. (2009). NIH Public Access. *Archives of Ophthalmology*, *126*(10), 1336–1349.
- Momeni-Moghaddam, H., Kundart, J., Azimi, A., & Hassanyani, F. (2015). The effectiveness of home-based pencil push-up therapy versus office-based therapy for the treatment of symptomatic convergence insufficiency in young adults. *Middle East African Journal of Ophthalmology*, *22*(1), 97.
- Nehad, T., Salem, T., & Elmohamady, M. N. (2018). Combined Office-based Vergence Therapy and Home Therapy System for Convergence Insufficiency in Egyptian Children. *The Open Ophthalmology Journal*, *12*(1), 12–18.
- Noorden, V., & GK. (, 2002). Examination of the patient-IV : Amblyopia. *Binocular Vision and Ocular Motility : Theory and Management of Strabismus*, 246–297.
- Norn, M. S. (1966). Convergence insufficiency: Incidence in Ophthalmic Practice. Re stilts of Orthoptic Treatment. *Acta Ophthalmologica*, *44*(2), 132–138.
- Rosenbaum, A. L., & Santiago, A. P. (1999). *Clinical strabismus management : principles and surgical techniques*. Saunders.
- Rouse, M., Borsting, E., Mitchell, G. L., Cotter, S. A., Kulp, M., Scheiman, M., ... Manny, R. (2009). The validity of the convergence insufficiency symptom survey: A confirmatory study. *Optometry and Vision Science* *86*(4)357-363.
- Rouse, M. W., Borsting, E., Hyman, L., Hussein, M., Cotter, S. A., Flynn, M., ... De Land, P. N. (1999). Frequency of convergence insufficiency among fifth and sixth graders. The Convergence Insufficiency and Reading Study (CIRS) group. *Optometry and Vision Science*, *76*(9)643-649.
- Sathyan (2017). *Major Review Convergence insufficiency*. 88–95.

- Scheiman. (2016). Convergence Insufficiency in Children : *American Academy Of Optometry*, 93(12), 1457–1465.
- Scheiman, M., Cotter, S., Rouse, M., Mitchell, G. L., Kulp, M., Cooper, J., & Borsting, E. (2005). A randomized clinical trial of the effectiveness of base-in prism reading glasses versus placebo reading glasses for symptomatic convergence insufficiency in children. *British Journal of Ophthalmology* 89(10),1318-1323.
- Scheiman, Mitchell, Cooper, J., Mitchell, G. L., Land, P. De, Cotter, S., Borsting, E., ... &Rouse, M. (2002). A survey of treatment modalities for convergence insufficiency. *Optometry and Vision Science*, 79(3), 151–157.
- Scheiman, Mitchell, Cotter, S., Kulp, M. T., Mitchell, G. L., Cooper, J., Gallaway, M., ... &Convergence Insufficiency Treatment Trial Study Group. (, 2011). Treatment of accommodative dysfunction in children: results from a randomized clinical trial. *Optometry and Vision Science*, 88(11), 1343–1352.
- Scheiman, Mitchell, Cotter, S., Mitchell, G. L., Kulp, M., Rouse, M., Hertle, R., ... &Tamkins, S. (2008). A randomized clinical trial of treatments for symptomatic convergence insufficiency in children. *Archives of Ophthalmology*126(10), 1336.
- Scheiman, Mitchell, Mitchell, G. L., Cotter, S., Cooper, J., Kulp, M., Rouse, M., ... &Wensveen, J. (2005a). A randomized clinical trial of treatments for convergence insufficiency in children. *Archives of Ophthalmology* 123(1),14.
- Scheiman, Mitchell, Mitchell, G. L., Cotter, S., Cooper, J., Kulp, M., Rouse, M., ... &Wensveen, J. (2005b). A randomized clinical trial of treatments for convergence insufficiency in children. *Archives of Ophthalmology*, 123(1), 14–24.
- Scheiman, Mitchell, Mitchell, G. L., Cotter, S., Cooper, J., Kulp, M., Rouse, M., ... &Wensveen, J. (2005c). A randomized clinical trial of treatments for convergence insufficiency in children. *Archives of Ophthalmology* 123(1),14-24.

- Scheiman, Mitchell, Mitchell, G. L., Cotter, S., Kulp, M., Rouse, M., Hertle, R., ... & Gallaway, M. (2008). The convergence insufficiency treatment trial: design, methods, and baseline data. *Ophthalmic Epidemiology*, *15*(1), 24-36.
- Shippman, S., Infantino, J., Cimbol, D., Cohen, K. R., & Weseley, A. C. (1983). Convergence Insufficiency With Normal Parameters. *Journal of Pediatric Ophthalmology and Strabismus*, *20*(4), 158–161.
- Singh, N. K., Mani, R., & Hussaindeen, J. R. (2017). Cambios del ratio AC/A estímulo y respuesta tras con terapia visual en casos de Insuficiencia de Convergencia. *Journal of Optometry*, *10*(3), 169–175.
- Sreenivasan, V., & Bobier, W. R. (2014). Reduced vergence adaptation is associated with a prolonged output of convergence accommodation in convergence insufficiency. *Vision Research*, *100*, 99–104.
- Sreenivasan, V., & Bobier, W. R. (2015). The increased onset of vergence adaptation reduces excessive accommodation during the orthoptic treatment of convergence insufficiency. *Vision Research*, *111*, 105–113.
- Stidwill, D. (1997). Epidemiology of strabismus. *Ophthalmic & Physiological Optics*, *17*(6), 536–539.
- Sweeney, L. E., Seidel, D., Day, M., & Gray, L. S. (2014). Quantifying interactions between accommodation and vergence in a binocularly normal population. *Vision Research*, *105*, 121–129.
- Sweeney, L. E., Seidel, D., Day, M., Gray, L. S., Vienne, C., Sorin, L., ... The article, O. (2014). Visión binocular en el Siglo XXI. *Vision Research*, *105*(3), 14–24.
- Theodore Grosvenor, T. P. (2007). *Primary Care Optometry*
- Triantafilou, M., D., Welder D., J., & Longmuir Q., S. *Convergence Insufficiency*. (, 2014).
- Ukai, K., & Howarth, P. A. (2008). Visual fatigue caused by viewing stereoscopic motion images: Background, theories, and observations. *Displays* *29*(2), 106-116.

- Van Leeuwen, A. F., Westen, M. J., van der Steen, J., de Faber, J.-T. H. ., & Collewijn, H. (1999). Gaze-shift dynamics in subjects with and without symptoms of convergence insufficiency: influence of monocular preference and the effect of training. *Vision Research*, 39(18), 3095–3107.
- Vasudevan, B., Ciuffreda, K. J., & Ludlam, D. P. (2009). Accommodative training to reduce near work-induced transient myopia. *Optometry and Vision Science*, 86(11), 1287–1294.
- Wajuihian, S. O. (2018). Normative values for clinical measures used to classify accommodative and vergence anomalies in a sample of high school children in South Africa. *Journal of Optometry* 123(3), 143-160.
- Wajuihian, S. O., & Hansraj, R. (2016). Vergence anomalies in a sample of high school students in South Africa. *Journal of Optometry*, 9(4), 246–257.
- Werner, L., Trindade, F., Pereira, F., & Werner, L. (2000). Physiology of Accommodation and Presbyopia. *Arquivos Brasileiros De Oftalmologia*, 63(6), 503–509.
- Wick, B., Yothers, T. L., Jiang, B.-C., & Morse, S. E. (2002). Clinical testing of accommodative facility: Part 1. A critical appraisal of the literature. *Optometry (St. Louis, Mo.)* 73(1), 11- 23.
- Wright, K. W. (2003). pediatric ophthalmology and strabismus. In *Pediatric Ophthalmology and Strabismus pp 250 -277*.
- Zetterberg, C., Forsman, M., & Richter, H. O. (2013). Effects of visually demanding near work on trapezius muscle activity. *Journal of Electromyography and Kinesiology* 23(5),1190-1198

APPENDICES

APPENDIX I: INFORMED CONSENT (PARENTS/ LEGAL GUARDIANS)

You are humbly requested to give your permission to include your child in this study.

Parent/guardian statement

I have read this consent form or had the information read to me. I have had the chance to discuss this research study with a study counselor. I have had my questions answered by him or her in a language that I understand. The risks and benefits have been explained to me. I understand that I will be given a copy of this consent form after signing it. I understand that my participation and that of my child in this study is voluntary and that I may choose to withdraw it any time.

I understand that all efforts will be made to keep information regarding me and my child's identity confidential.

By signing this consent form, I have not given up my child's legal rights as a participant in this research study.

I voluntarily agree to my child's participation in this research study:

Yes **No**

I agree to have my child undergo all testing: Yes No

I agree to undergo vision therapy: Yes No

I agree to provide contact information for follow-up: Yes No

Parent/Guardian signature /Thumb stamp: _____ **Date** _____

Parent/Guardian **printed** **name:**

Researcher's statement

I, the undersigned, have fully explained the relevant details of this research study to the participant named above and believe that the participant has understood and has knowingly given his/her consent.

Name: _____ **Date:** _____ **Signature:** _____

APPENDIX II: ASSENT FORM

Signing your name at the bottom means that you agree to be in this study. If you are not able to sign your name, you do not have to. The investigator will continue to treat you whether or not you participate in this study. You will be given a copy of this form after you have signed it

I, _____ (Print your name) would like to be in this research study. _____ (Date of assent)_____

(Name of the investigator) _____(Signature of person who obtained assent and Date)

APPENDIX III: SUBJECT INSTRUCTIONS - PENCIL PUSH-UP (PENCIL PUSH-UP GROUP)

Equipment:

1. Alphabet pencil
2. White index card.
3. Centimeter ruler.

Procedure:

1. Stand or sit comfortably 6 to 8 feet in front of a wall. Attach the index card, oriented vertically (longest side pointing up and down), to the wall at eye level.
2. Hold the pencil at arm's length directly between you and the card on the wall while you look directly at the s/mall letter on the pencil. You should see one clear letter, one pencil, and two cards in the background.
3. Move the pencil slowly towards your nose while concentrating on the small letter.
4. Keep looking at the small letter on the pencil, but be aware of the two cards on the wall in the background with your peripheral (side) vision.
5. As the pencil approaches you, the cards should move apart and may appear to become smaller. If one of the cards disappears, stop moving the pencil and blink your eyes until both cards are in view.
6. Continue to look at the small letter while moving the pencil slowly towards your nose.

Try and keep it clear and single as long as possible. When you can no longer keep the small letter clear, continue to try and keep it single as you move it closer. When you can no longer keep it single (when it has become two), stop moving the pencil and try to get the letter back to one. If you cannot get the two letters back into one, slowly move the pencil away from you until you can bring the two letters together.

7. Once you can make the letters one again, continue moving the pencil closer to your nose.

If you cannot get the letters back into one, start the procedure over at step 2.

8. Spend 15 minutes per day, five days per week doing this exercise. Do the pencil push-up technique for three sets of 5 minutes. After completing each 5-minute session, measure the distance of the pencil to your brow, just above the bridge of your nose. Record this result in your log form.

The goal of the procedure is to get the pencil tip within 2 to 3 cm of your brow, just beyond the nose.

APPENDIX IV: INFORMATION DOCUMENT (PARENT/S)

Vision therapies and accommodation in patients with convergence insufficiency attending the Masinde Muliro University Academic Vision Centre, Kenya

ANDREW WEKESA (Principal Investigator)

I am pleased to inform you about the study entitled: Vision therapies and accommodation in patients with convergence insufficiency attending the Masinde Muliro University Academic Vision Centre, Kenya. This is an intervention study that has been conducted in other parts of the world. The purpose of this form is to give you the information you will need to help you decide whether or not your child should participate in the study. Feel free to ask any questions about the purpose of the research, what happens if your child participates in the study, the possible risks and benefits, the rigVTS4 of your child as a volunteer, and anything else about the research or if anything included in this form that is not clear. When we have answered all your questions to your satisfaction, you may decide if you want your child to be part of the study or not. Once you understand and agree for your child to partake in the study, I will request you to sign your name on the consent form below. You should understand the general principles which apply to all participants in medical research: i) Your child decides to participate entirely voluntary ii) Your child may withdraw from the study at any time without necessarily giving a reason for his/her withdrawal iii) Refusal to participate in the research will not affect the services your child is entitled to in this health facility or other facilities.

WHAT IS THE PURPOSE OF THE STUDY?

To determine the effects of vision therapies on accommodation types in patients with convergence insufficiency attending the Masinde Muliro University Academic Vision Center in Kenya. Participants will also undergo tests such as visual acuity and accommodation measurements.

There will be approximately 50 randomly selected participants in this study. We therefore humbly request you to consider your child to participate in this study.

WHAT WILL HAPPEN IF YOU DECIDE YOU WANT YOUR CHILD TO BE INCLUDED IN THIS RESEARCH STUDY?

If you agree for your child to participate in this study, the following things will happen:

You will be handled by a trained optometrist in a private area where you feel comfortable undergoing the therapy. The treatment will last approximately 55 minutes.

WHAT IF YOU HAVE QUESTIONS IN FUTURE?

If you have further questions or concerns about your child participating in this study, please call or send a text message to the study team members at the numbers provided at the bottom of this page.

For more information about your child's rigVTS4 as a research participant, you may contact the Secretary/Chairperson, Masinde Muliro University Ethics and Review Committee Telephone No. 056-31375, Email ierc@mmust.ac.ke.

The study staff will pay you back for your charges to these numbers if the call is for study-related communication.

APPENDIX V: INFORMATION DOCUMENT (CHILDREN)

Vision therapies and accommodation in patients with convergence insufficiency attending the Masinde Muliro University Academic Vision Centre, Kenya.

ANDREW WEKESA (Principal Investigator)

What is the reason for this study?

The study is all about treating your eye for the condition known as convergence insufficiency, which means the failure of your eyes to work together at near for a long time.

Why should I be asked to join this study?

We are inviting you to be in the study because the treatment has worked elsewhere in the world and the easiest among other treatment protocols. Since you have the same condition, it will be beneficial to you as you participate.

What if I have a question?

You can ask questions if you do not understand any part of the study. If you have questions later that you don't think of now, you can talk to me again or ask your parent or guardian to call me.

Will I be hurt if I am in the study?

Since the study does not involve taking some samples, the only thing that will be experienced is a mild headache since there will be exercise on your muscle which will only last for a short period.

What happens after the study?

After the study is completed, the report will be written, and we will not include your name or indicate that you participated.

APPENDIX VI: APPROVAL LETTER FROM POSTGRADUATE STUDIES



MASINDE MULIRO UNIVERSITY OF SCIENCE AND TECHNOLOGY (MMUST)

Tel: 056-30870
Fax: 056-30153
E-mail: directordps@mmust.ac.ke
Website: www.mmust.ac.ke

P.O Box 190
Kakamega – 50100
Kenya

Directorate of Postgraduate Studies

Ref: MMU/COR: 509099

22nd August, 2019

Andrew Wekesa,
H01/G/01- 55815/2016,
P.O. Box 190-50100,
KAKAMEGA.

Dear Mr. Wekesa,

RE: APPROVAL OF PROPOSAL

I am pleased to inform you that the Directorate of Postgraduate Studies has considered and approved your masters proposal entitled: *“Effects of Convergence Insufficiency Vision Therapies on Accommodation in Patients Attending Masinde Muliro University Academic Vision Centre, Kenya”* and appointed the following as supervisors:

1. Prof. Khathutshelo Percy Mashige - University of Kwazulu - Natal
2. Dr. Maximilla Wanzala - SPHBST, MMUST

You are required to submit through your supervisor(s) progress reports every three months to the Director Postgraduate Studies. Such reports should be copied to the following: Chairman, School of Public Health, Biomedical Sciences and Technology Graduate Studies Committee and Chairman, Optometry and Vision Sciences Department. Kindly adhere to research ethics consideration in conducting research.

It is the policy and regulations of the University that you observe a deadline of two years from the date of registration to complete your master’s thesis. Do not hesitate to consult this office in case of any problem encountered in the course of your work.

We wish you the best in your research and hope the study will make original contribution to knowledge.

Yours Sincerely,

Prof. John Obiri
DIRECTOR, DIRECTORATE OF POSTGRADUATE STUDIES

APPENDIX VII: APPROVAL LETTER FROM INSTITUTIONAL ETHICS REVIEW COMMITTEE

MASINDE MULIRO UNIVERSITY OF SCIENCE AND TECHNOLOGY
Tel: 056-31375 P. O. Box 190-50100
Fax: 056-30153 Kakamega, Kenya
E-mail: ierc@mmust.ac.ke
Website: www.mmust.ac.ke

Institutional Ethics Review Committee (IERC)

Ref: MMU/COR: 403012 vol2 (53)

Date: 20th September, 2019

Andrew Wekesa

Masinde Muliro University of Science and Technology
P.O.Box 190-50100
KAKAMEGA

Dear Mr. Wekesa

RE: Effects of convenience insufficiency vision therapies on accommodation in patients attending Masinde Muliro University Academic Vision Centre-MMUST/IERC/76 /19

Thank you for submitting your proposal entitled as above for initial review. This is to inform you that the committee conducted the initial review and approved (with minor revisions) the above Referenced application for one year.

This approval is valid from **20th September, 2019 through to 20th September, 2020**. Please note that authorization to conduct this study will automatically expire on **20th September, 2020**. If you plan to continue with data collection or analysis beyond this date please submit an application for continuing approval to the MMUST IERC by **20th August, 2020**.

Approval for continuation of the study will be subject to submission and review of an annual report that must reach the MMUST IERC secretariat by **20th August, 2020**. You are required to submit any amendments to this protocol and any other information pertinent to human participation in this study to MMUST IERC prior to implementation.

Please note that any unanticipated problems or adverse effects/events resulting from the conduct of this study must be reported to **MMUST IERC**. Also note that you are required to seek for research permit from **NACOSTI** prior to the initiation of the study.

Yours faithfully,







Dr. Gordon Nguka (PhD)

Chairman, Institutional Ethics Review Committee

Copy to:

- The Secretary, National Bio-Ethics Committee
- Vice Chancellor
- DVC (PR&I)
- DVC (A & F)

APPENDIX VIII: APPROVAL FROM NACOSTI

 REPUBLIC OF KENYA	 NATIONAL COMMISSION FOR SCIENCE, TECHNOLOGY & INNOVATION
Ref No: 764913	Date of Issue: 09/January/2020
RESEARCH LICENSE	
	
This is to Certify that Mr. Andrew wekesa of Masinde Muliro University of Science and Technology, has been licensed to conduct research in Kakamega on the topic: EFFECTS OF CONVERGENCE INSUFFICIENCY VISION THERAPIES ON ACCOMMODATION IN PATIENTS ATTENDING MASINDE MULIRO UNIVERSITY ACADEMIC VISION CENTRE, KENYA for the period ending : 09/January/2021.	
License No: NACOSTI/P/20/3094	
764913	
Applicant Identification Number	Director General NATIONAL COMMISSION FOR SCIENCE, TECHNOLOGY & INNOVATION
	Verification QR Code
	
NOTE: This is a computer generated License. To verify the authenticity of this document, Scan the QR Code using QR scanner application.	

THE SCIENCE, TECHNOLOGY AND INNOVATION ACT, 2013

The Grant of Research Licenses is Guided by the Science, Technology and Innovation (Research Licensing) Regulations, 2014

CONDITIONS

1. The License is valid for the proposed research, location and specified period
2. The License any rights thereunder are non-transferable
3. The Licensee shall inform the relevant County Director of Education, County Commissioner and County Governor before commencement of the research
4. Excavation, filming and collection of specimens are subject to further necessary clearance from relevant Government Agencies
5. The License does not give authority to transfer research materials
6. NACOSTI may monitor and evaluate the licensed research project
7. The Licensee shall submit one hard copy and upload a soft copy of their final report (thesis) within one of completion of the research
8. NACOSTI reserves the right to modify the conditions of the License including cancellation without prior notice

National Commission for Science, Technology and Innovation
off Waiyaki Way, Upper Kabete,
P. O. Box 30623, 00100 Nairobi, KENYA
Land line: 020 4007000, 020 2241349, 020 3310571, 020 8001077
Mobile: 0713 788 787 / 0735 404 245
E-mail: dg@nacosti.go.ke / registry@nacosti.go.ke
Website: www.nacosti.go.ke